

Redefine your comfort zone.™ | [www.titus-hvac.com](http://www.titus-hvac.com)



## critical environment



healthcare

hospitals

surgical

cleanrooms

research labs



# r

**CRITICAL ENVIRONMENT PRODUCTS**

Critical Environment Products ..... R4

**OVERVIEW**

Overview ..... R8  
 Applications ..... R8  
 General Cleanroom Information ..... R8  
 Air Motion ..... R8  
 Air Volume ..... R9  
 Air Filtration and Quality Control ..... R10  
 Proper Equipment ..... R10  
 Personnel Training ..... R10

**RADIAL PATTERN**

VersaTec ..... R11  
 Overview ..... R11  
 Dimensions ..... R12  
 Performance Data ..... R13  
 TriTec ..... R14  
 Overview ..... R14  
 Dimensions ..... R16  
 Performance Data ..... R17  
 TriTecR ..... R18  
 Overview ..... R18  
 Dimensions ..... R20  
 Accessories ..... R21  
 Performance Data ..... R23  
 RadiaTec ..... R24  
 Overview ..... R24  
 Dimensions ..... R26  
 Performance Data ..... R27

**HORIZONTAL PATTERN**

TDCR ..... R30  
 Overview ..... R30  
 Dimensions ..... R31  
 Accessories ..... R32  
 Performance Data ..... R34

**LAMINAR PATTERN**

TLF ..... R35  
 Overview ..... R35  
 Dimensions ..... R36  
 Performance Data ..... R37  
 TLF-LED ..... R38  
 Overview ..... R38  
 Dimensions ..... R39  
 Wiring Digram ..... R40  
 Performance Data ..... R41  
 TLFR ..... R42  
 Overview ..... R42  
 Dimensions ..... R43  
 Accessories ..... R44  
 Performance Data ..... R46  
 TLFR-LED ..... R52  
 Overview ..... R52  
 Dimensions ..... R53  
 Accessories ..... R54  
 Performance Data ..... R56

**LINEAR AIR CURTAIN**

LineaTec .....	R62
Overview .....	R62
Dimensions .....	R63
Performance Data.....	R66
SteriTec.....	R67
Overview .....	R67
Dimensions .....	R69
Linear Plenum Details.....	R70
Flange and Hanger Bracket Details.....	R71
Plenum Inlet Locations.....	R72

**OPERATING ROOM CEILING SYSTEM**

AORCS .....	R73
Dimensions.....	R74

**OPERATING ROOM SUITE**

NEXUS OR Suite .....	R75
----------------------	-----

**FAN FILTER DIFFUSERS**

Fan Filter Diffusers .....	R76
Dimensions.....	R77
Options & Accessories .....	R79
Performance Data.....	R81

**ACCESSORIES**

Accessories .....	R83
HEPA Filter .....	R83
HEPA-R Filter.....	R85
MERV14-R.....	R86
MERV15-R.....	R90
ULPA-R.....	R91

**APPLICATION NOTES**

Application Notes.....	R92
Titus Operating Room Air Distribution System .....	R92
System Sizing & Layout.....	R92
Operating Room Air Distribution System.....	R93

**CLEANROOM TERMINOLOGY**

Basic Cleanroom Terminology.....	R94
----------------------------------	-----

**ICONS**

Icons Key .....	R104
-----------------	------

PAGES: R11-R29

radial pattern



RadiaTec-AL / RadiaTec-SS

**RADIAL PATTERN DIFFUSER**

- Designed for cleanroom applications
- Delivers high volumes of air at low velocity
- Fixed radial discharge pattern with 1-way or 2-way option
- Optional HEPA filter rack available



TriTec / TriTec-AL / TriTec-SS / TriTecR

**RADIAL PATTERN DIFFUSER**

- Designed for cleanroom applications
- Delivers high volumes of air at low velocity
- Fixed radial discharge pattern with 1-way or 2-way option



VersaTec / VersaTec-AL

**RADIAL PATTERN DIFFUSER**

- Designed for cleanroom applications
- Delivers high volumes of air at low velocity
- Radial discharge pattern is adjustable using face mounted louvers

PAGES: R30-R34

horizontal pattern

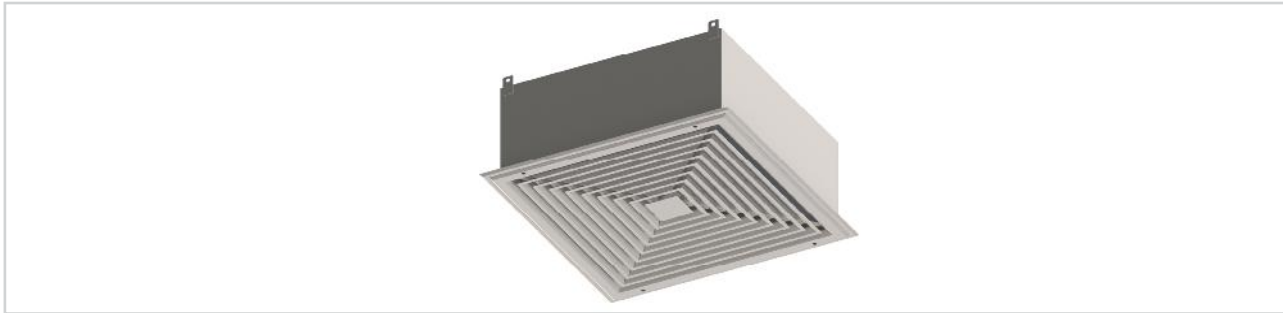

TDCR

**HORIZONTAL PATTERN DIFFUSER**

- Ideal for installation in laboratory spaces and anterooms
- Snap-in, tool-less filter installation and removal
- Factory pressure tested
- Fully welded construction option
- Roomside accessible PAO challenge port option
- Louvered face quickly removes by loosening quarter-turn fasteners
- Retainer cables prevent the perforated face from falling after removal

PAGES: R35-R41



TLF / TLF-AA / TLF-SS

**LAMINAR PATTERN DIFFUSER**

- Industry standard for unidirectional airflow diffuser
- For use in clean air environments such as operating rooms
- Laminar flow pattern minimizes induction and entrainment of room air
- Steel, aluminum or stainless steel construction
- Optional TRM mounting frame available for surface mounting

laminar pattern

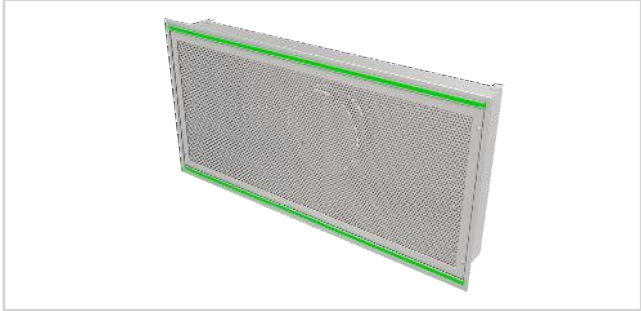

TLF-LED

**LAMINAR PATTERN DIFFUSER**

- Integrated high-output, high-efficiency LED Lighting
- Industry standard for unidirectional airflow diffuser
- Non-aspirating design for creation of sterile workspaces
- Aluminum or stainless steel construction

PAGES: R42-R61

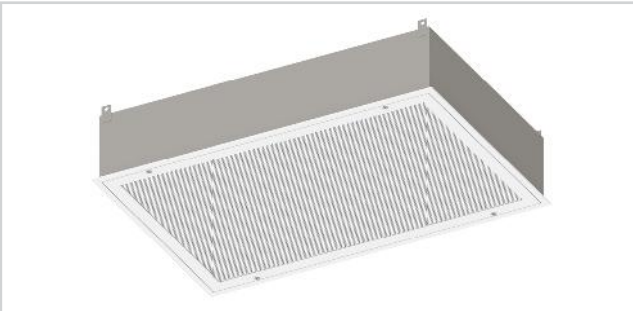

TLFR

**LAMINAR PATTERN DIFFUSER**

- Industry standard for unidirectional airflow diffuser
- For use in clean air environments such as operating rooms
- Laminar flow pattern minimizes induction and entrainment of room air
- Snap-in filter, autocentering filter retainers
- 2", 3", and 4" filter media thicknesses
- Optional remote operated dampers
- Optional aerosol challenge port and manifold

laminar pattern

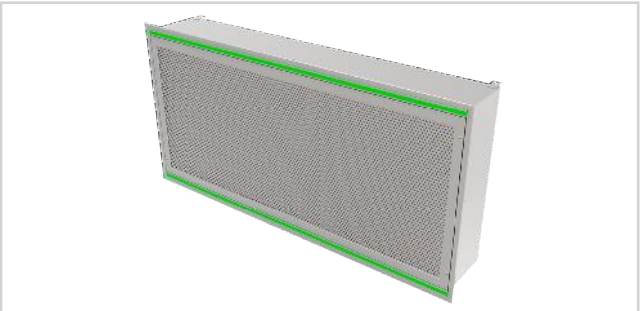

TLFR-LED

**LAMINAR PATTERN DIFFUSER**

- Integrated high-output, high-efficiency LED Lighting
- Industry standard for filtered unidirectional airflow diffuser
- Non-aspirating design for creation of sterile workspaces
- Snap-in filter, autocentering filter retainers
- 2", 3", and 4" filter media thicknesses
- Aluminum or stainless steel construction
- Optional remote operated dampers
- Optional aerosol challenge port and manifold

PAGES: R62-R72

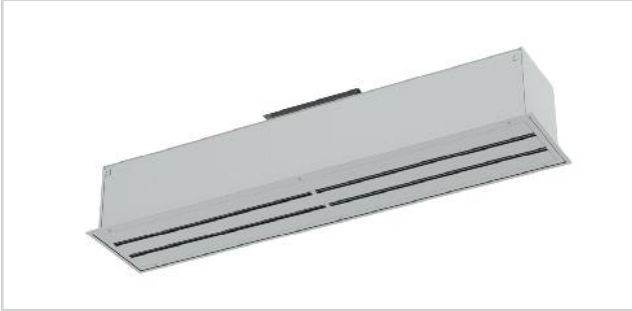

LineaTec-AL / LineaTec-SS

**LINEAR AIR CURTAIN DIFFUSER**

- For use in clean air environments like operating rooms
- Creates air curtain barrier between clean zone and balance of room
- Optional plenums available with round corners for ease of cleaning
- Aluminum or stainless steel construction

linear air curtain

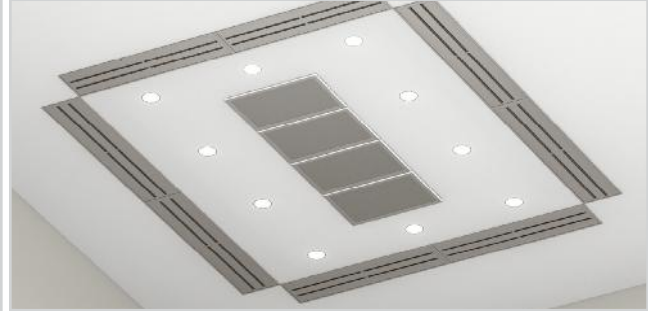

SteriTec-AL / SteriTec-SS

**STERILE ENVIRONMENT SYSTEM**

- SteriTec system combines LineaTec diffusers to form a clean zone within a cleanroom
- Corner transitions are full plenum size creating no airflow restriction
- Continuous plenums minimize duct runs
- Aluminum or stainless steel construction

PAGES: R73-R74

operating room ceiling system



AORCS

**AORCS**

- Ideal for use in operating rooms, cleanrooms, laboratories, & pharmacies
- Extruded aluminum construction
- Rapid assembly with “quick snap” connectors
- Factory supplied blank-off panels to match air distribution equipment

PAGES: R75

operating room suite



NEXUS OR SUITE

**NEXUS OR SUITE**

- Available in a heavy-duty model that can accommodate a wide range of suspended equipment
- Heavy-duty model, Nexus OR Suite-S, and includes stamped, structural calculations provided with each configuration
- Helps to comply with ASHRAE 170 - Ventilation in Health Care Facilities
- Pre-engineered, modular design is ideal for retrofit projects, as the system offers fast and quiet installation with minimal disruption to surrounding areas
- Specifically designed to make the best use of the limited ceiling space by integrating LED lighting within laminar airflow diffusers

PAGES: R94-R98

room air cleaner





THRC



**ROOM AIR CLEANER**

- Ideal airflow pattern delivers clean air to the breathing zone
- 560 CFM – 800 CFM High Flow Configuration
- 70 CFM – 400 CFM Low Flow Configuration
- 99.99% Medical Grade HEPA Filter
- 99.995% ULPA Filtration Option
- Antimicrobial MERV 8 Pre-filter
- Filter Replacement Indicator Light
- Quiet operation and simple maintenance
- Durable welded steel cabinet
- Optional High Intensity UV-C Germicidal Lighting
- Locking Caster Wheels

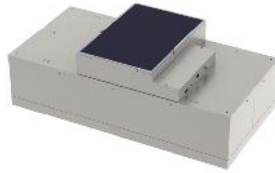
PAGES: R76-R82

fan filter diffusers

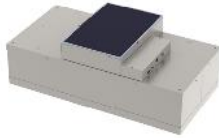
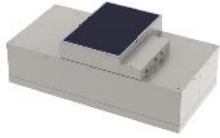
			
<p style="text-align: center;"><b>FFD</b></p> <p><b>FAN FILTER DIFFUSER</b></p> <ul style="list-style-type: none"> <li>• Unique solution for cleanroom environments</li> <li>• PSC motor</li> <li>• Solid state speed control</li> <li>• Low profile design</li> <li>• Aluminum or stainless steel construction</li> </ul>	<p style="text-align: center;"><b>FFDE</b></p> <p><b>FAN FILTER DIFFUSER</b></p> <ul style="list-style-type: none"> <li>• Unique solution for cleanroom environments</li> <li>• ECM motor</li> <li>• Solid state speed control</li> <li>• Low profile design</li> <li>• Aluminum or stainless steel construction</li> </ul>	<p style="text-align: center;"><b>FFDB</b></p> <p><b>FAN FILTER DIFFUSER</b></p> <ul style="list-style-type: none"> <li>• Unique solution for cleanroom environments</li> <li>• ECM motor</li> <li>• Backward curved fan</li> <li>• Solid state speed control</li> <li>• Low profile design</li> <li>• Aluminum or stainless steel construction</li> </ul>	<p style="text-align: center;"><b>FFDR</b></p> <p><b>FAN FILTER DIFFUSER</b></p> <ul style="list-style-type: none"> <li>• Unique solution for cleanroom environments</li> <li>• PSC motor</li> <li>• Solid state speed control</li> <li>• Roomside replaceable HEPA filter</li> <li>• Low profile design</li> <li>• Aluminum or stainless steel construction</li> </ul>

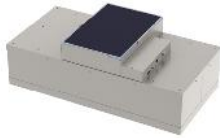
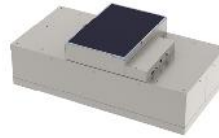
				
<p style="text-align: center;"><b>FFDER</b></p> <p><b>FAN FILTER DIFFUSER</b></p> <ul style="list-style-type: none"> <li>• Unique solution for cleanroom environments</li> <li>• ECM motor</li> <li>• Digital speed control</li> <li>• Roomside replaceable HEPA filter</li> <li>• Low profile design</li> <li>• Aluminum or stainless steel construction</li> </ul>	<p style="text-align: center;"><b>FFDBR</b></p> <p><b>FAN FILTER DIFFUSER</b></p> <ul style="list-style-type: none"> <li>• Unique solution for cleanroom environments</li> <li>• ECM motor</li> <li>• Backward curved fan</li> <li>• Digital speed control</li> <li>• Roomside replaceable HEPA filter</li> <li>• Low profile design</li> <li>• Aluminum or stainless steel construction</li> </ul>	<p style="text-align: center;"><b>FFDRA</b></p> <p><b>FAN FILTER DIFFUSER</b></p> <ul style="list-style-type: none"> <li>• Unique solution for cleanroom environments</li> <li>• Roomside replaceable PSC motor</li> <li>• Solid state speed control</li> <li>• Roomside replaceable HEPA filter</li> <li>• Low profile design</li> <li>• Aluminum or stainless steel construction</li> </ul>	<p style="text-align: center;"><b>FFDERA</b></p> <p><b>FAN FILTER DIFFUSER</b></p> <ul style="list-style-type: none"> <li>• Unique solution for cleanroom environments</li> <li>• Roomside replaceable ECM motor</li> <li>• Digital speed control</li> <li>• Roomside replaceable HEPA filter</li> <li>• Low profile design</li> <li>• Aluminum or stainless steel construction</li> </ul>	<p style="text-align: center;"><b>FFDBRA</b></p> <p><b>FAN FILTER DIFFUSER</b></p> <ul style="list-style-type: none"> <li>• Unique solution for cleanroom environments</li> <li>• Roomside replaceable ECM motor</li> <li>• Backward curved fan</li> <li>• Digital speed control</li> <li>• Roomside replaceable HEPA filter</li> <li>• Low profile design</li> <li>• Aluminum or stainless steel construction</li> </ul>



### APPLICATIONS

Titus representatives have installed diffusers in cleanrooms and in clean areas throughout the entire country for over 25 years. Many operating rooms and research laboratories as well as numerous other facilities have Titus environmental diffusers.

Cleanrooms include hospital operating rooms, electronics manufacturing, pharmaceutical and biotechnology manufacturing, research facilities, automotive painting and many other applications.

### GENERAL CLEANROOM INFORMATION

Design criteria for cleanrooms include cleanliness classification desired, air volume requirements, air motion, proper filtration and removal of contaminants, properly designed equipment and personnel training. Titus products are designed to help the engineer with the proper air distribution requirements and air motion.

Contamination comes from two sources: external and internal. External sources include incoming air, wall penetrations for pipes, ducts and other HVAC equipment.

Internal sources include personnel, process equipment, manufacturing processes and material ingress.

No matter what source has contributed to the unwanted particle count, the design of the cleanroom or clean area facilitates the control of incoming particles and eliminates particles within the environmental envelope.

### AIR MOTION

Motion is critical to control concentrations of particles in the entire cleanroom or in a particular area of the room. Air motion is either unidirectional, also called laminar, or multi-directional. The figure to the right shows typical cleanroom airflow patterns. Unidirectional air motion is used to push unwanted particles out of the controlled space. Multi-directional air motion can be used to remove unwanted particles by dilution.

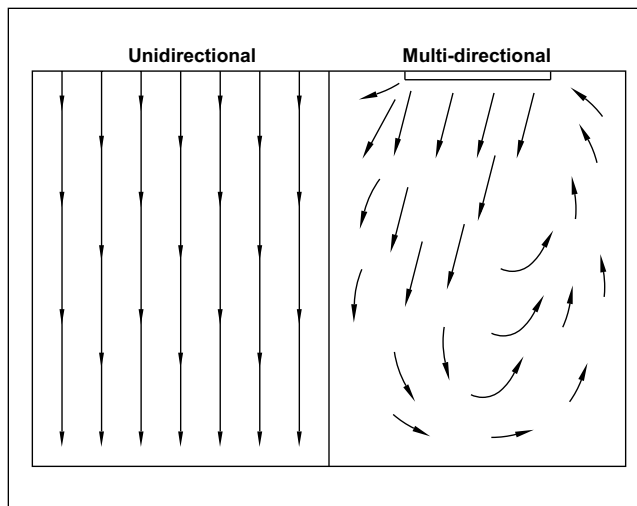

Typical Airflow Patterns in Cleanroom



When using multi-directional air motion the designer is depending solely on dilution to achieve the desired cleanliness level. Although dilution may reduce particle levels in the entire room to a moderate average level, it does not ensure that any given area in the room is controlled to acceptable particulate levels.

Unidirectional flow can be used to provide clean airflow over an obstruction and push particles to a floor return plenum. Return grilles can be located in the floor of the room and can be exhausted as shown in the figure, Unidirectional Flow. In many cases, however, codes require the return air grille to be mounted in the lower side-wall of the room. This allows the floors to be mopped and cleaned for standard conditions. For operating rooms, the return grilles should be mounted with their lower frame at least 8 inches above the floor in the far corners of the room.

In many cleanrooms work areas are designed with unidirectional flow. Fume hoods may obtain supply air from directly inside the room immediately adjacent to the fume hood while exhausting the air externally. The maximum allowable air velocity in front of fume hoods must be less than the capture velocity of the hood. This room velocity is generally about 15 to 35 fpm, helping to ensure the air within the fume hood is not induced out of the hood and into the room. Proper location of air devices helps further reduce unwanted air motion. The placement of the diffuser can be critical and care should be taken to avoid entrainment of fumes from hoods into the laboratory. Special short throw diffusers can be used in these locations to eliminate high velocities from moving across the face of the hoods. Typical hood capture velocities are about 100 fpm.

Whether unidirectional or multi-directional airflow patterns are utilized, air velocities in the clean area must be controlled. Particles 0.5 micrometers and larger tend to quickly settle on the floor or other work surfaces due to gravity. These particles are easily disturbed and re-entrained into the cleanroom atmosphere, thereby recontaminating a previously clean area. To control re-entrainment, air velocities at the floor area should be below 50 fpm.

### AIR VOLUME

Air volume is a key to creating and sustaining any given class of a cleanroom. Large volumes of clean air are used to dilute contaminated air. In other words, contaminated air is slowly displaced by clean, treated air. As more clean air is brought into the room and contaminated air is removed from the room, the clean air dilutes the contaminated air. This process slowly reduces the particle level in the room. Volume is determined by the job engineer according to standard industry practices, experience, and situational requirements. It is common to specify 10 to 40 air changes per hour in a critical environment. ISO Class 1 to 5 cleanrooms may have air change rates as high as 300 to 600 air changes per hour.

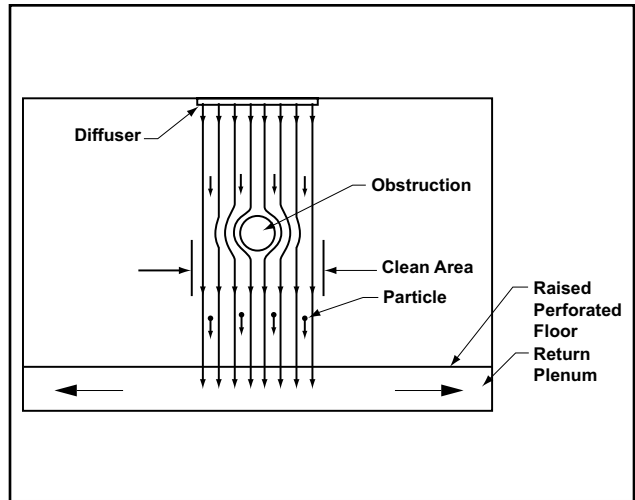

Unidirectional Flow (ISO Class 1 to 5)

Filter Designation and Efficiency Level

Name	Designation	Efficiency	Max Particle Size
High-Efficiency Filter	HE	95%	0.3μ
High-Efficiency Particulate Filter	HEPA	99.99%	0.3μ
Ultra-Low Penetration Air Filter	ULPA	99.9995%	0.12μ

AIR FILTRATION AND QUALITY CONTROL

All cleanrooms utilize filtration systems to purify incoming air and/or recirculated air. These systems usually include prefilters that are low cost and easily replaceable. Prefilters are the first step in extracting or trapping unwanted particles from the air.

Upstream of the high-efficiency particulate (HEPA) or ultra-low penetration (ULPA) air filters, prefilters of 30 percent and then 85 percent greatly reduce the amount of contaminants that need to be eliminated by HEPA or ULPA filters. The chart on this page classifies commonly designated filters and their efficiencies.

For cleanroom ISO classes 6 to 8, regardless of the filter classification specified, several principles should be considered prior to application. The best place for high-efficiency filters is upstream of the air outlets in a remote location. If the high-efficiency filter is an integral part of the air distribution device, removal of the filter should be accomplished from outside the protected zone. Working with the filter in the protected zone creates a high probability of contaminating the clean zone.

Volume control dampers should be located upstream of the high-efficiency filter so that operation of the damper does not contaminate the airstream.

Chemical filtration may also be included. The filter media is typically activated carbon.

Air quality includes temperature and humidity control. Elaborate systems have been developed by the industry to control these two factors. Humidity is typically controlled somewhere around 50%. Temperature control specifications may be within 1° F or less.

Pressurization of the cleanroom or clean zone also contributes to air quality. Higher pressure clean zones help reduce infiltration of contaminants from outside sources. The typical room differential pressure specified is 0.05 inch wg according to ISO 14644-1. Most critical environmental rooms have positive pressurization to keep contamination out of these areas.

PROPER EQUIPMENT

Equipment and construction materials may emit contamination. Equipment utilized in cleanrooms is typically 304 stainless steel. Internal construction is engineered to retard outflow of contaminants from sources such as bearings, plastics and other decaying material or moving parts.

Air showers or tunnels may be provided for personnel entering the controlled zone. Air curtains may be used to also protect the clean zone.

Cleaning equipment such as high efficiency vacuum cleaners, tack cloths, lint-free cleaning cloths and autoclaves all contribute to the overall cleanliness of the room or area.

PERSONNEL TRAINING

Proper cleanroom etiquette is critical to maintaining a clean environment. Protocol for entering the room and leaving the room must be maintained. Movement within the room must be controlled. Sudden movements by personnel can entrain settled contaminated particles back into the clean airstream.

Titus has a complete line of diffusers designed for applications requiring unidirectional or multi-directional airflow. Laboratories, operating rooms, electronics manufacturing, pharmaceutical and biotechnology manufacturing, automotive painting and many other applications can benefit from using Titus Critical Environment Diffusers.

## Radial Pattern

## critical environment diffusers

### VersaTec

- Uses specially formed adjustable blades for maximum free area and directional throw
- High airflow capacity (200 to 800 cfm)
- Available in 24 x 24" or 48 x 24" module sizes
- Individually adjustable louvers
- Backpan not visible from below
- Louvers direct airflow slightly below ceiling level
- 24 x 24" has 10" inlet 48 x 24" has 12" inlet
- Perforated or louvered center section
- Available for laying into standard T-bar ceiling grids. Surface mounted units are laid into a Titus TRM frame.
- Internal air baffling to equalize airflow across the face of the diffuser



VERSATEC



cleanrooms

research labs



See website for Specifications

### MODELS:

VersaTec / Steel Backpan with Aluminum Blades

VersaTec-AL / Aluminum Backpan with Aluminum Blades

### FINISHES:

Standard Finish - #26 White

Optional Finish - #04 Mill

### OVERVIEW

Hemispherical Air Diffusion Using Adjustable Blades

VersaTec models feature adjustable pattern control technology for delivering high volumes of low velocity air in a radial pattern. Each model is constructed using adjustable blades which allow adjustment of the discharge air pattern. Two versions of this model are available; VersaTec with an optional adjustable blade face and VersaTec with a perforated center section. VersaTec diffuser blades drops less than 1" below the ceiling.

These diffusers are an excellent choice for ISO Class 6 to 8 spaces. Applications include cleanroom environments such as labs with exhaust hoods, pharmaceutical manufacturing and biotechnology research.

#### VersaTec with adjustable blade face

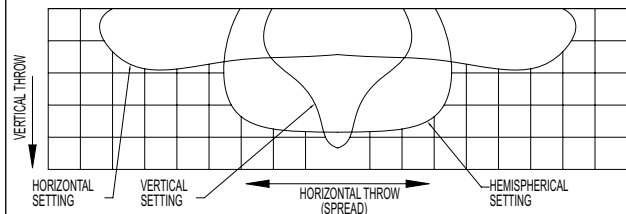

#### VersaTec with perforated center section

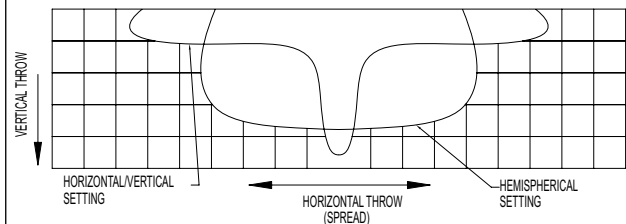

VERSATEC UNIT DIMENSIONS

VersaTec with perforated center section

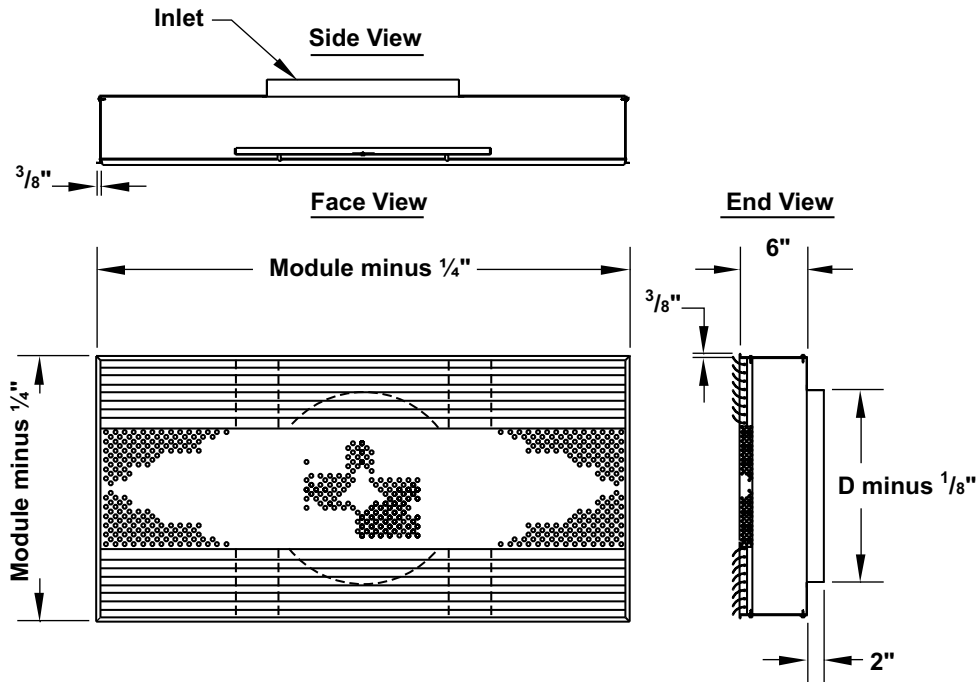

VersaTec with optional adjustable blade face

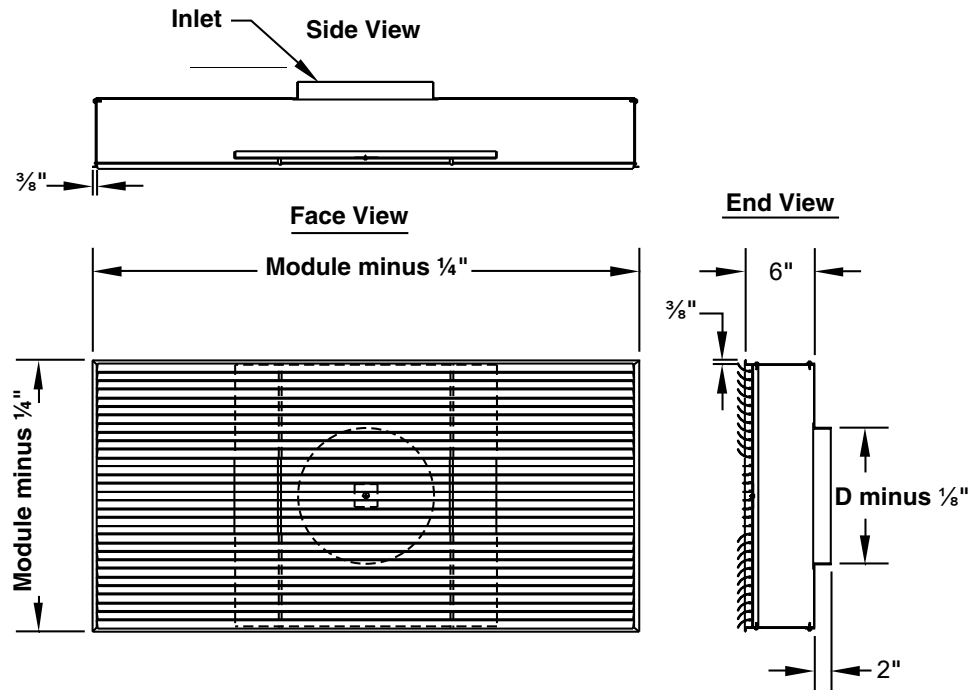

R

DIMENSIONS

VERSATEC AND VERSATEC-AL

		Discharge Pattern						
		Hemispherical			Horizontal (Spread)			
		200	300	400	200	300	400	
24" x 24" 10" Inlet	cfm	200	300	400	200	300	400	
	NC	21	25	27	22	27	29	
	Total Pressure	0.02	0.07	0.14	0.04	0.09	0.16	
	5° FΔT	Horizontal Throw	1-1-1	1-1-2	1-2-3	2-4-6	4-5-9	5-7-12
		Vertical Throw	1-1-2	1-2-4	2-3-5	2-3-6	3-5-7	4-6-9
	15° FΔT	Horizontal Throw	1-1-1	1-1-2	1-1-2	2-3-5	2-4-8	5-6-10
		Vertical Throw	1-1-3	1-2-5	2-4-6	2-3-8	3-5-8	4-7-10
48" x 24" 12" Inlet	cfm	400	600	800	400	600	800	
	NC	23	28	30	26	31	33	
	Total Pressure	0.05	0.10	0.18	0.05	0.13	0.24	
	5° FΔT	Horizontal Throw	1-2-4	2-3-6	3-4-7	3-4-7	5-6-8	5-6-13
		Vertical Throw	1-2-3	2-3-5	2-4-7	1-3-4	2-3-6	3-4-7
	15° FΔT	Horizontal Throw	1-2-3	2-3-5	3-3-6	3-4-5	4-5-6	5-5-11
		Vertical Throw	1-3-5	2-4-7	2-4-8	1-3-6	2-4-8	3-5-9

- Throws are to terminal velocities of 100, 50 and 25 fpm. See the section, Engineering Guidelines and the topic Procedure to Obtain Catalog Throw Data in this catalog for throw information.
- The horizontal throw is the distance of the overall width of the jet.
- Use above performance data table for optional curved blade center section.
- NC is the noise criteria curve that will not be exceeded in octave bands 2 thru 7. The NC assumes a 10 db room absorption.
- Air patterns between the two shown in the isovel diagrams on the previous page can be obtained by adjustment of the blades.

## TriTec

- Removable face for sanitizing (no special tool required to remove the face)
- Available in steel, 304 stainless steel, or aluminum with 304 stainless steel face
- Available in 24 x 24" and 48 x 24" module sizes
- Low velocity hemispherical pattern or one-way hemispherical pattern available
- Factory supplied back pan with every unit
- 22-gauge backpan
- Available in inlet sizes of 8" or 10" for 24 x 24" module sizes, 10" or 12" for 24 x 48" module sizes
- Standard unit lays into standard T-bar ceiling grids. Optional TRM mounting frame available for surface mounting.

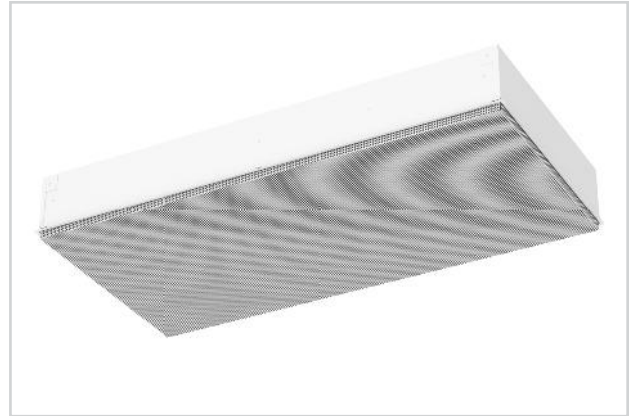

TRITEC



cleanrooms



research labs



See website for Specifications

### MODELS:

- TriTec / Steel Face and Backpan
- TriTec-AL / 304 Stainless Steel Face with Aluminum Backpan
- TriTec-SS / 304 Stainless Steel Face and Backpan

### FINISHES:

- Standard Finish - #26 White
- Optional Finish - #04 Mill

### OVERVIEW

High Volume, Low Velocity, Radial Air Diffusion Technology

TriTec models are designed to allow large volumes of air to be brought into the environment with very short throws.

Discharging airflow patterns of a two-way blow provide a 180 degree radial pattern, TriTec takes advantage of the maximum space available for distributing velocity. This results in the lowest possible velocities for the volume of air being delivered. Unlike competitive models, TriTec takes advantage of a 51 percent free area perforated face which in appearance looks like industry standard perforated diffusers.

TriTec's unique design allows it to create a full pattern in the middle of the diffuser as well as on the ends. The design of the TriTec allows these diffusers to be mounted end to end without increasing the throw.

Applications include labs with exhaust hoods, pharmaceutical manufacturing, telephone switching rooms, biotechnology research and many other applications where high airflows with short throws are required. This diffuser has a very high induction rate. These diffusers are an excellent choice for ISO Class 6 to 8 spaces.

Air enters the diffuser and is spread across the entire diffuser by the

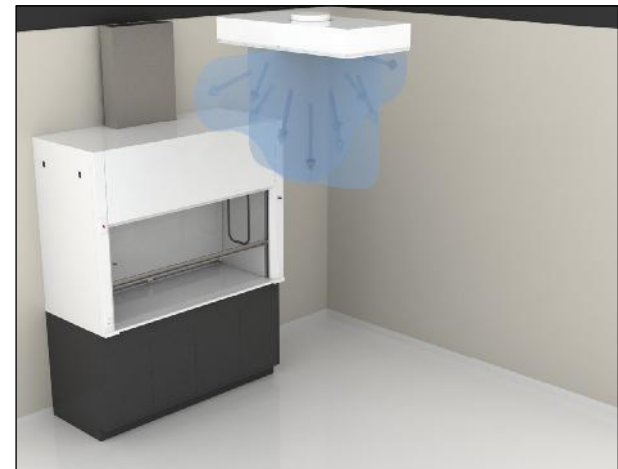

Rendering of the TriTec diffuser air pattern with a nearby fume hood in the room

pressure induction plate. As air passes through the pressure induction plate it expands into the air dampening chamber. While passing through the air dampening chamber, long fixed blades direct the air creating a hemispherical air pattern as the air passes through the 51 percent free area face.

### ADVANTAGES

- Simple to install and maintain
- Great for use in fume hood areas
- Earthquake tabs supplied as standard
- Retainer cable supplied with every unit
- 51 percent free area perforated face matches industry standard perforated diffuser's appearance

TriTec Laboratory Application - Side View

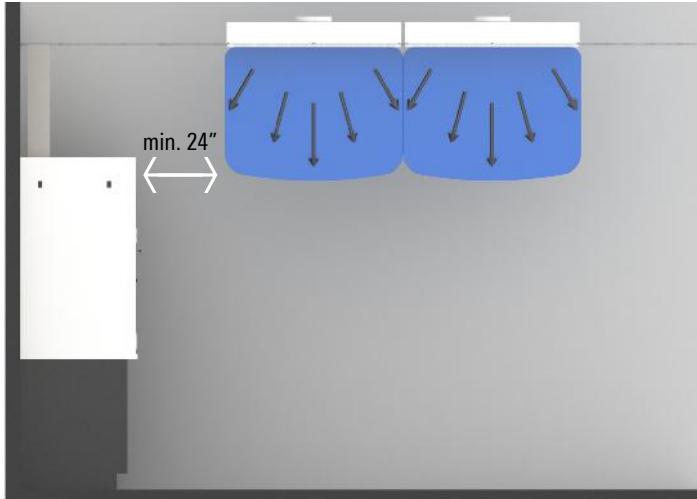

TriTec Laboratory Application - Plan View

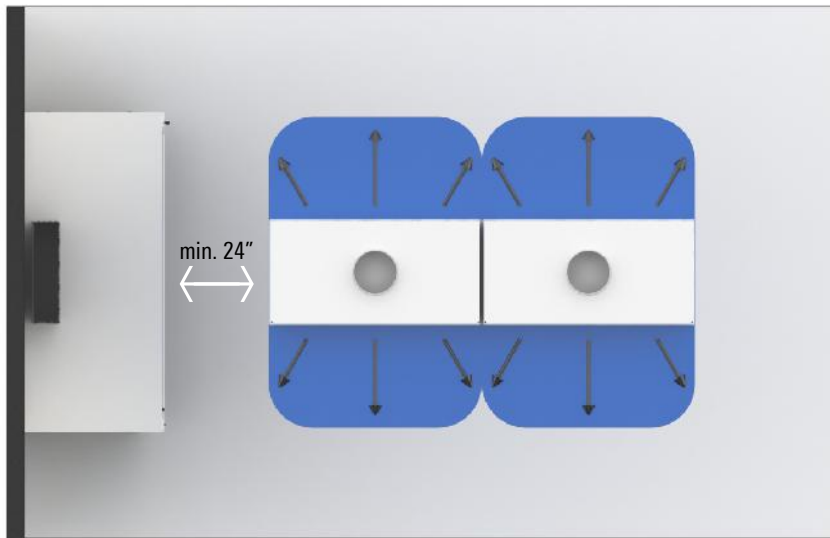

TriTec Laboratory Application - End View





DIMENSIONS

TRITEC UNIT DIMENSIONS

TriTec Layout

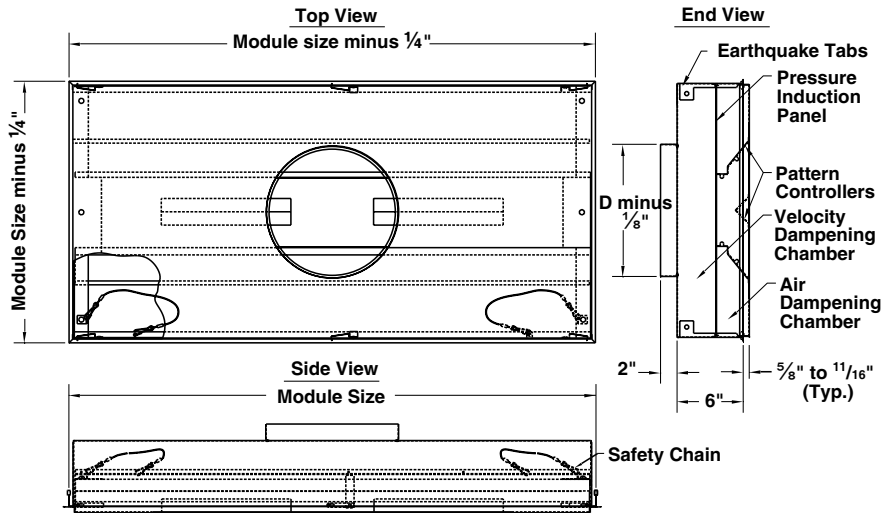

TriTec Lay-In Application

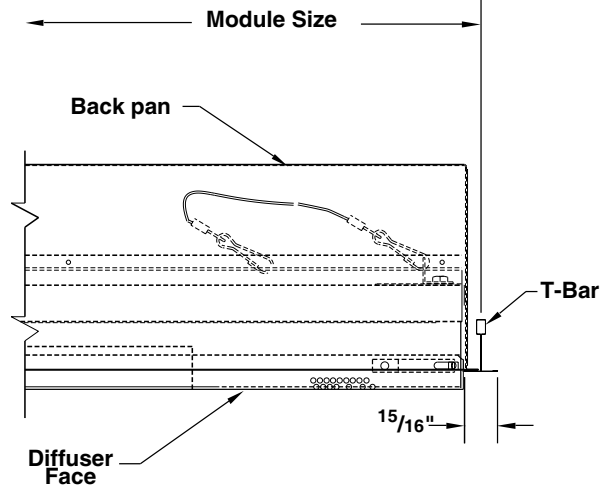

Surface Mount Application with Optional TRM Rapid Mount Frame

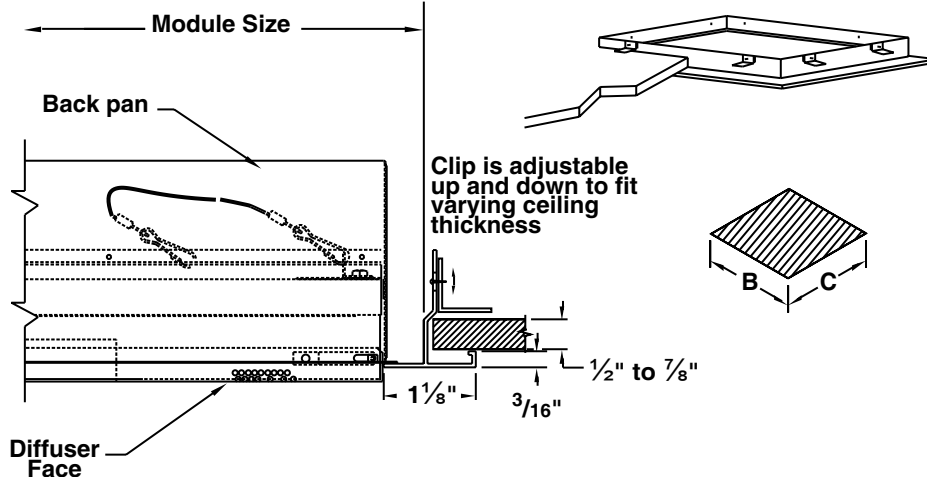

TRITEC, TRITEC-AL AND TRITEC-SS

Module Size and Inlet Size	2-Way Pattern				Horizontal Spread (ft)			Vertical Throw (ft)								
								5 Deg ΔT			10 Deg ΔT			15 Deg ΔT		
	cfm	Ps	Pt	Nc	100-75-50			100-75-50			100-75-50			100-75-50		
24" X 24" 8" Inlet	250	0.055	0.087	25	1	2	5	1	2	3	1	2	3	1	2	4
	300	0.080	0.126	29	2	3	6	1	3	4	1	2	4	2	3	5
	400	0.142	0.224	37	3	5	7	3	3	5	2	4	5	3	5	7
	500	0.222	0.350	42	5	6	8	3	4	5	3	5	7	4	6	8
24" X 24" 10" Inlet	250	0.026	0.039	<20	1	1	3	0	1	2	0	1	2	1	1	2
	300	0.037	0.056	20	1	2	4	1	1	2	1	1	3	1	1	3
	475	0.093	0.140	31	3	5	7	1	3	6	2	3	6	2	4	7
	600	0.148	0.224	37	4	6	9	2	4	8	3	5	8	3	6	9
24" X 48" 10" Inlet	375	0.054	0.084	<20	3	4	6	0	1	1	1	1	2	1	1	2
	500	0.097	0.149	26	4	6	9	1	1	3	1	2	4	1	2	4
	700	0.190	0.292	39	6	8	10	1	2	5	2	4	6	2	4	7
	900	0.313	0.483	48	8	10	12	2	4	7	3	5	8	3	6	9
24" X 48" 12" Inlet	500	0.054	0.080	20	1	2	4	1	1	2	1	1	3	1	2	4
	650	0.092	0.135	24	2	3	7	1	2	4	1	2	5	2	3	6
	750	0.122	0.179	34	2	4	9	1	2	5	2	3	6	2	4	7
	1000	0.218	0.319	44	4	7	11	2	4	6	3	5	8	4	6	9
Module Size and Inlet Size	1-Way Pattern				Horizontal Spread (ft)			Vertical Throw (ft)								
								5 Deg ΔT			10 Deg ΔT			15 Deg ΔT		
	cfm	Ps	Pt	NC	100-75-50			100-75-50			100-75-50			100-75-50		
24" X 24" 8" Inlet	250	0.055	0.087	<20	1	2	3	0	0	1	1	1	2	1	1	3
	325	0.094	0.148	29	2	3	4	0	1	2	1	2	4	1	2	5
	400	0.142	0.224	35	3	3	4	1	1	3	2	3	6	2	4	8
	450	0.179	0.283	38	3	4	4	1	1	3	2	3	9	3	5	9
24" X 24" 10" Inlet	250	0.025	0.038	<20	1	2	4	1	1	3	1	1	3	2	3	7
	350	0.049	0.075	22	3	4	6	1	2	5	2	3	6	4	6	9
	450	0.081	0.123	28	4	5	7	2	4	6	3	5	7	6	8	9
	550	0.121	0.184	34	4	6	8	3	5	7	4	6	9	7	9	9
24" X 48" 10" Inlet	500	0.092	0.144	24	1	2	3	1	2	4	1	2	4	3	6	9
	625	0.143	0.225	32	2	2	4	2	3	5	2	3	6	5	8	9
	750	0.206	0.324	39	2	3	4	2	4	6	2	4	7	7	9	9
	900	0.297	0.467	44	3	4	6	4	5	8	4	7	9	8	9	9
24" X 48" 12" Inlet	500	0.051	0.076	<20	1	2	3	2	4	7	4	6	8	4	6	8
	650	0.086	0.129	25	2	3	4	4	6	9	6	7	9	6	7	9
	750	0.114	0.171	31	3	3	5	5	7	9	6	8	9	6	8	9
	1000	0.203	0.304	42	3	5	7	7	9	9	8	9	9	8	9	9

- Spread is the maximum width of the isovel at the indicated terminal velocity
- Vertical throw is the furthest distance below the ceiling where the indicated terminal velocity can be measured
- Tests were conducted in a 16 x 16-foot room, with a 9-foot ceiling, low side wall returns, in accordance with ASHRAE Standard 113-2013, in several planes

- Low emissivity heaters were used to maintain loads, and were set to match the supply air conditions. The room was free of obstructions during the tests.
- Sound and pressure drop tests were conducted in accordance with ASHRAE Standard 70-2006 and ANSI S1.31 Procedures

2-WAY PATTERN

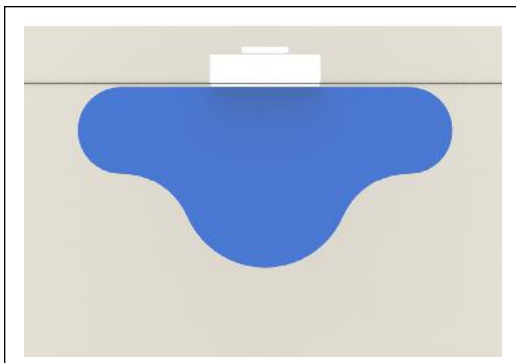

1-WAY PATTERN



## TriTecR

- Ideal for installation in laboratory and isolation rooms
- Snap-in, tool-less HEPA filter installation and removal
- Factory pressure tested
- Fully welded construction option
- Roomside accessible PAO challenge port option
- Perforated face quickly removes by loosening quarter-turn fasteners
- Retainer cables prevent the perforated face from falling after removal
- Low velocity hemispherical or one-way hemispherical pattern available
- Accommodates filters with 2", 3", & 4" media packs [Model HEPA-R]
- Compatible with 1" or 1½" T-bar ceiling grids
- Optional TRM mounting frame available for surface mounting

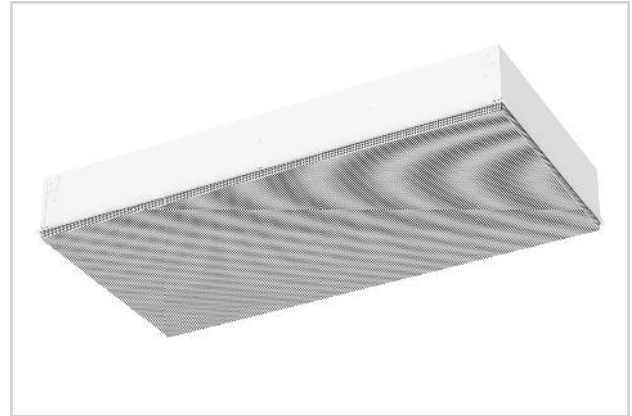

TRITECR



cleanrooms



research labs

### MODELS:

TriTecR-AL / 304 Stainless Steel Face with Aluminum Backpan  
TriTecR-SS / 304 Stainless Steel Face and Backpan

### FINISHES:

Standard Finish - #26 White and #04 Mill  
Optional Finish - #84 Black

### OVERVIEW

Ultra Clean, High Volume, Low Velocity, Radial Air Diffusion Technology

TriTecR models are designed to allow large volumes of HEPA filtered air to be brought into the environment with very short throws. Including snap-in, autocentering filter retainers, the TriTecR reduces the amount of time and effort during installation and removal of filters. This decreases the time a lab is out of commission, allowing facilities to maximize profitability and patient care.

Discharging airflow patterns of a two-way blow provide a 180 degree radial pattern, TriTecR takes advantage of the maximum space available for distributing velocity. This results in the lowest possible velocities for the volume of air being delivered. TriTecR's unique design allows it to create a full pattern in the middle of the diffuser as well as on the ends. The design of the TriTecR allows these diffusers to be mounted end to end without increasing the throw.

Applications include labs with exhaust hoods, pharmaceutical manufacturing, biotechnology research and many other applications where an elevated volume of clean airflow is required to purge contaminants from the space without disturbing or disrupting the processes being performed. The very high induction rate of the TriTecR diffuser results in the shortest throw possible to mitigate impact on



See website for Specifications

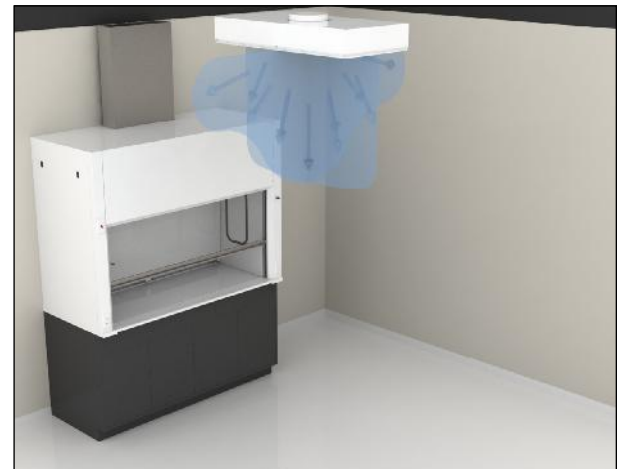

Rendering of the TriTecR diffuser air pattern with a nearby fume hood in the room

specialized equipment and processes. These diffusers are an excellent choice for ISO Class 5 to 8 spaces.

TriTecR Laboratory Application - Side View

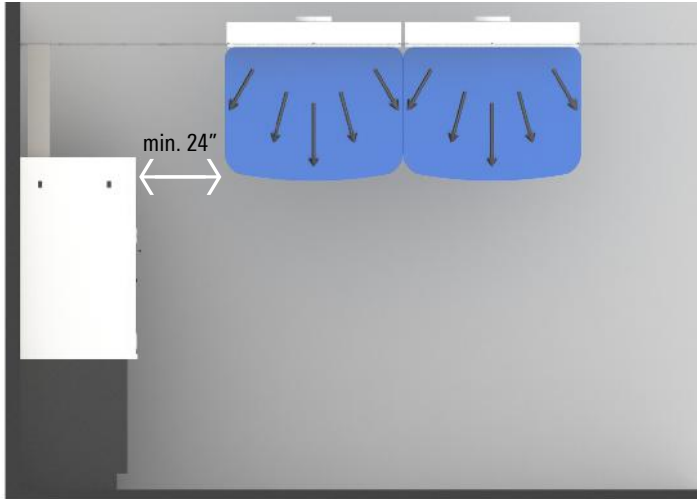

TriTecR Laboratory Application - Plan View

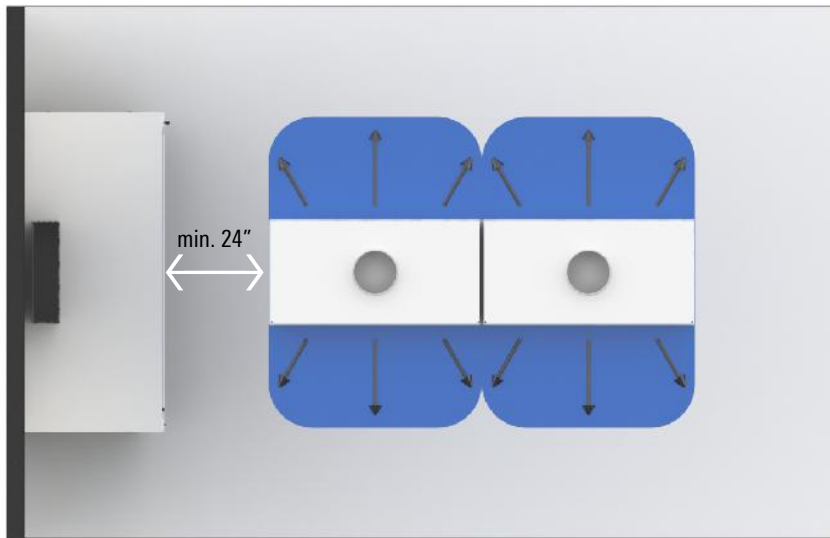

TriTecR Laboratory Application - End View





OPTIONAL ACCESSORIES

Cable Operated Damper Detail

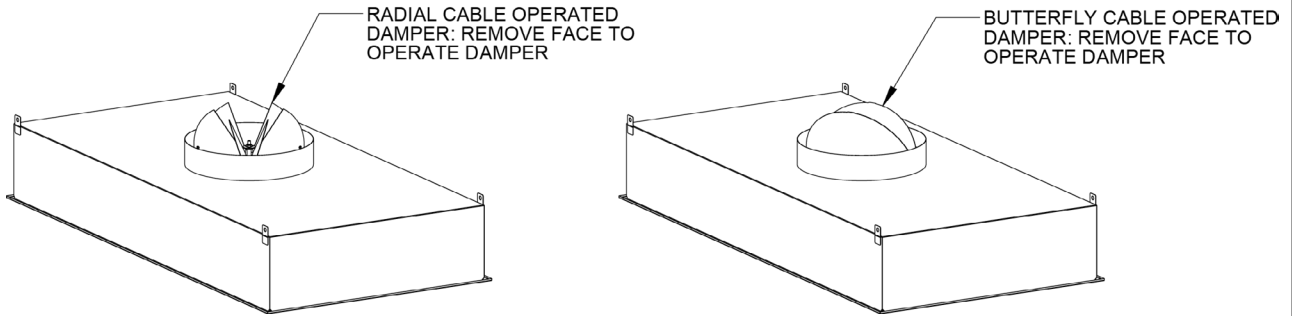

Port & Cable Operator Details

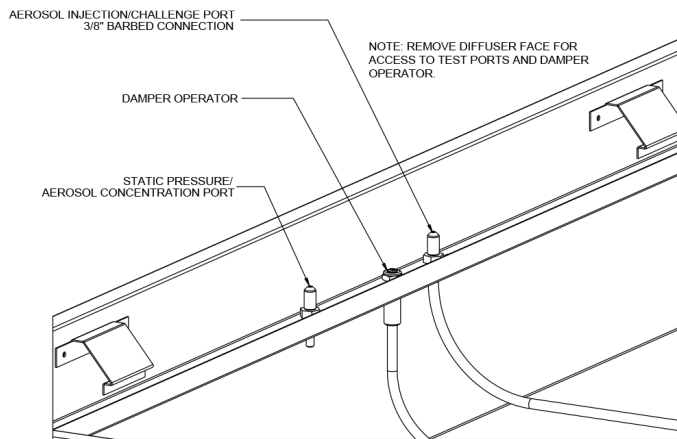

Aerosol Manifold Details

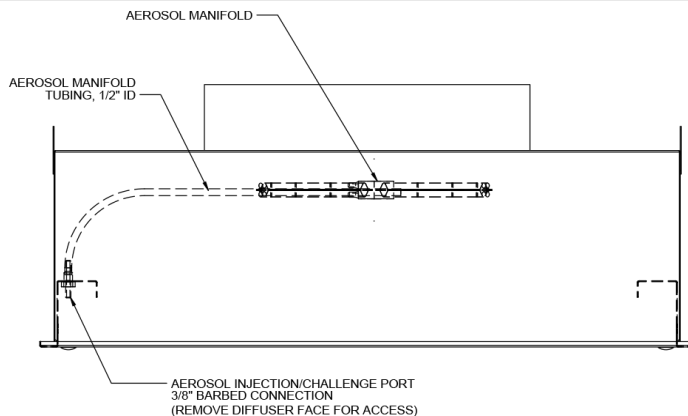

OPTIONAL ACCESSORIES

Knife Edge/Gel Seal Detail

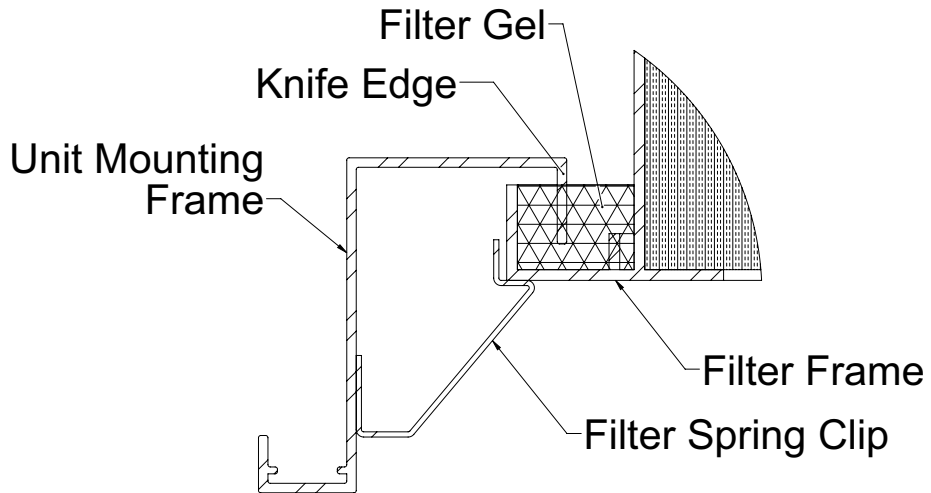



TRITECR-AL / TRITECR-SS

Module and Inlet Size	2-Way Pattern				Horizontal Spread			Vertical Throw (ft)								
					(ft)			5 Deg ΔT			10 Deg ΔT			15 Deg ΔT		
	cfm	Ps	Pt	Nc	100-75-50			100-75-50			100-75-50			100-75-50		
24" x 24" 8" Inlet	150	0.19	0.20	--	1	1	2	0	1	1	0	1	2	0	1	2
	200	0.33	0.35	--	1	1	2	1	1	1	1	1	2	1	1	2
	300	0.94	0.99	28	1	2	3	1	2	2	1	2	3	1	2	3
	400	1.85	1.94	37	2	3	4	1	3	4	2	3	4	2	4	5
24" x 24" 10" Inlet	150	0.20	0.21	--	1	1	2	0	1	1	0	1	2	0	1	2
	200	0.32	0.34	--	1	1	2	1	1	1	1	1	2	1	1	2
	300	0.91	0.93	22	1	1	2	1	2	2	1	2	3	1	2	4
	400	1.78	1.82	30	1	2	3	1	3	5	2	3	5	2	4	6
48" x 24" 10" Inlet	300	0.10	0.12	--	1	1	2	0	1	1	0	1	1	0	1	2
	400	0.13	0.17	26	1	2	3	1	1	2	1	2	2	1	2	3
	500	0.30	0.36	30	2	3	4	1	2	3	1	2	3	1	3	4
	600	0.52	0.60	35	2	3	4	1	2	4	1	2	5	2	4	6
	700	0.81	0.92	39	3	4	5	2	2	5	2	3	6	2	4	6
48" x 24" 12" Inlet	400	0.10	0.14	--	0	1	2	1	1	2	1	2	2	1	2	3
	500	0.25	0.28	22	1	1	2	1	2	3	1	2	4	2	3	5
	600	0.46	0.50	25	1	2	3	1	2	4	1	2	5	2	3	6
	700	0.72	0.77	29	1	2	4	1	2	5	2	3	6	2	4	7
	800	1.03	1.10	33	2	3	4	2	3	5	2	4	7	3	5	8

Module and Inlet Size	1-Way Pattern				Horizontal Spread			Vertical Throw (ft)								
					(ft)			5 Deg ΔT			10 Deg ΔT			15 Deg ΔT		
	cfm	Ps	Pt	Nc	100-75-50			100-75-50			100-75-50			100-75-50		
24" x 24" 8" Inlet	150	0.18	0.27	--	1	1	2	0	1	1	0	1	2	0	1	2
	200	0.31	0.32	--	1	2	3	1	1	2	1	2	2	1	2	3
	300	0.87	0.88	27	1	3	4	1	2	3	1	2	3	2	3	4
	400	1.71	1.72	35	2	3	4	2	3	5	2	3	5	3	4	7
24" x 24" 10" Inlet	150	0.19	0.20	--	1	1	3	0	1	1	0	1	2	1	1	2
	200	0.31	0.32	--	1	2	4	1	1	2	1	2	2	1	2	3
	300	0.87	0.88	22	2	3	5	1	2	3	1	2	4	2	3	4
	400	1.71	1.74	30	3	4	6	2	3	5	2	3	6	4	5	8
48" x 24" 10" Inlet	300	0.09	0.11	--	1	1	2	1	2	3	2	3	4	3	4	6
	400	0.12	0.16	25	1	2	3	2	4	6	3	4	6	4	5	7
	500	0.29	0.34	30	1	2	3	3	4	6	3	5	7	4	6	8
	600	0.50	0.56	34	2	2	4	3	5	7	5	6	7	5	6	8
	700	0.77	0.86	37	2	3	4	4	5	7	5	6	8	6	7	9
48" x 24" 12" Inlet	400	0.10	0.13	--	0	1	2	2	4	6	3	4	6	4	5	7
	500	0.24	0.27	22	1	2	3	3	4	7	4	5	7	4	6	8
	600	0.45	0.47	25	2	3	4	5	7	8	5	6	8	5	7	9
	700	0.69	0.73	28	3	3	5	4	6	8	6	7	9	6	8	9
	800	0.99	1.04	31	3	4	5	5	7	8	6	8	9	7	9	10

- Spread is the maximum width of the isovel from the diffuser centerline at the indicated terminal velocity
- Vertical throw is the furthest distance below the ceiling where the indicated terminal velocity can be measured
- Static pressure and total static pressure data includes initial resistance of HEPA-R filter with 2" media pack

- Tests were conducted in a 16 x 16-foot room, with a 9-foot ceiling, low side wall returns, in accordance with ASHRAE Standard 113-2013, in several planes
- Low emissivity heaters were used to maintain loads, and were set to match the supply air conditions. The room was free of obstructions during the tests.
- Sound and pressure drop tests were conducted in accordance with ASHRAE Standard 70-2006 and ANSI S1.31 Procedures

## RadiaTec

- Removable face for sanitizing from room-side (no special tool required)
- Available in aluminum and 304 stainless steel modular parts, (face and back pan can be of a different material)
- Available in 24 x 24" and 48 x 24" module sizes with one-way or two-way patterns
- Available inlet sizes: 8 or 10 inches for 24 x 24"; 10 or 12 inches for 48 x 24" modules
- Compatible with 1 or 1½" T-bar ceiling grids. Optional TRM mounting frame available for surface mounting.
- Unique baffling inside diffuser assures even air distribution across entire face
- Quarter-turn fasteners and retainer cables allow easy access for cleaning and filter replacement



RADIATEC



cleanrooms



research labs



See website for Specifications

### MODELS:

RadiaTec-AL / Aluminum Face and Backpan  
RadiaTec-SS / 304 Stainless Steel Face and Backpan

### FINISHES:

Standard Finish - #26 White  
Optional Finish - #04 Mill

### OVERVIEW

High Volume, Low Velocity, Radial Air Diffusion Technology

The RadiaTec diffuser is designed to meet the challenge of diluting airborne contaminants by supplying high-volume, low-velocity airflow to displace impurities. The airflow pattern is designed to produce a uniform pattern to prevent dead spots where contaminants can linger. In addition, the air pattern is tighter to the ceiling than competitive models to limit the air pattern penetration into the occupied zone.

The RadiaTec creates a full pattern along the face of the diffuser, and when mounted end-to-end, throw is not increased.

Applications include labs with exhaust fans, pharmaceutical manufacturing, biotechnology and other applications where high air volume with short flow are required. The RadiaTec's high induction rate draws impurities into its airstream, allowing it to be diluted to less harmful levels prior to exhausting the air. Excellent choice for ISO Class 6 to 8 spaces.

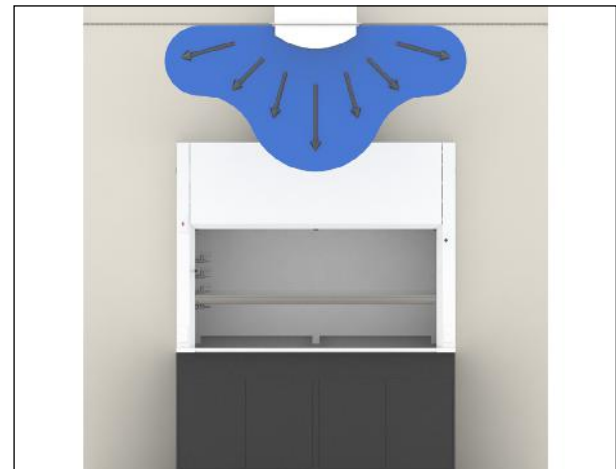

RadiaTec in Laboratory Application - End View

RadiaTec in Laboratory Application - Side View

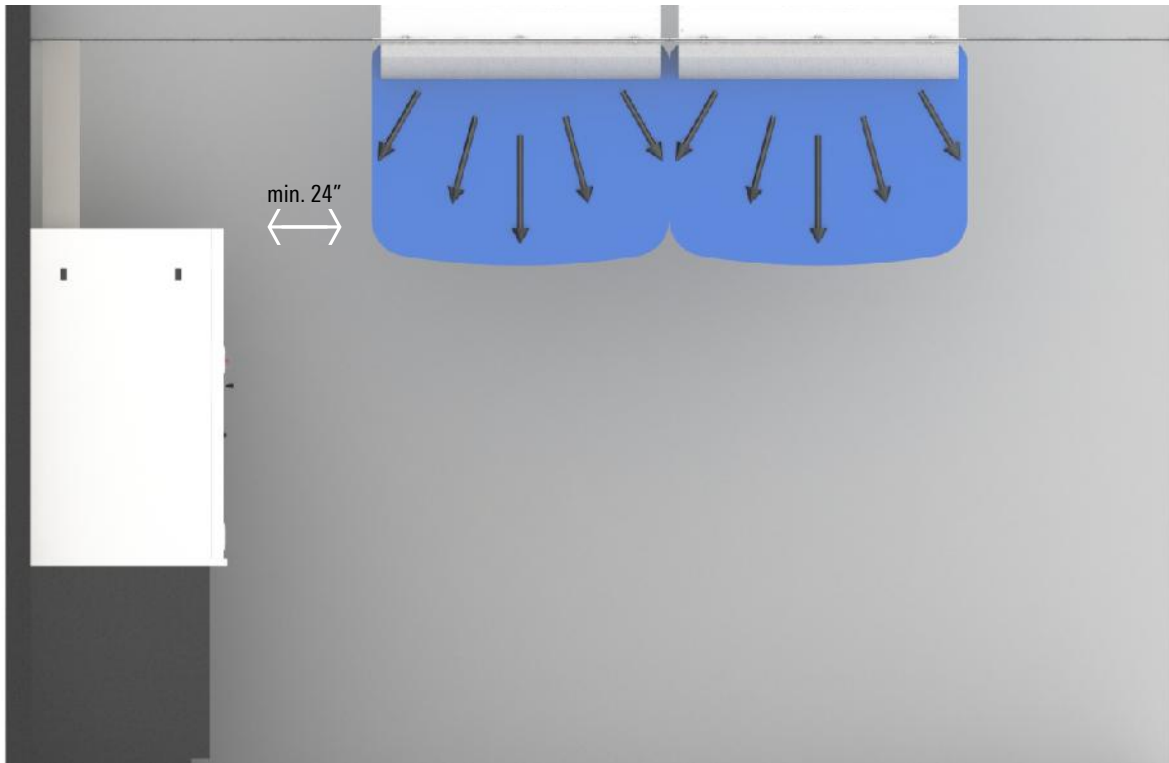

RadiaTec in Laboratory Application - Plan View

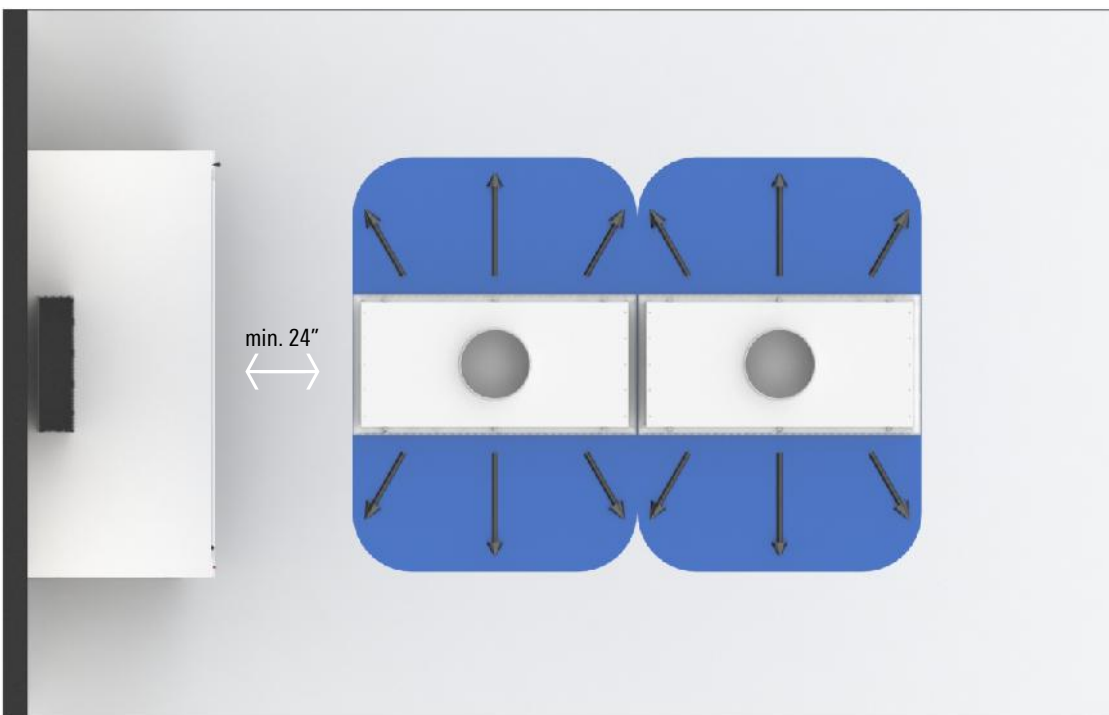

RADIATEC UNIT DIMENSIONS

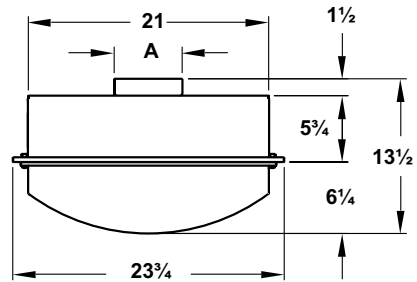
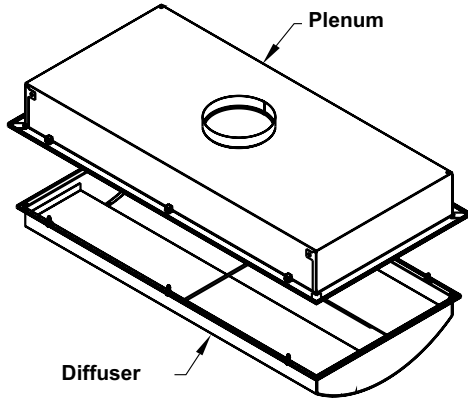

2-Way

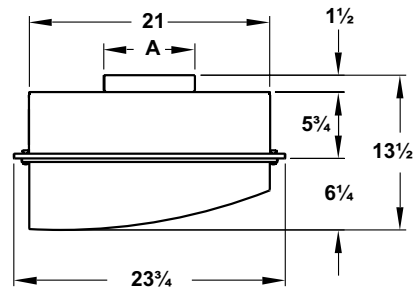
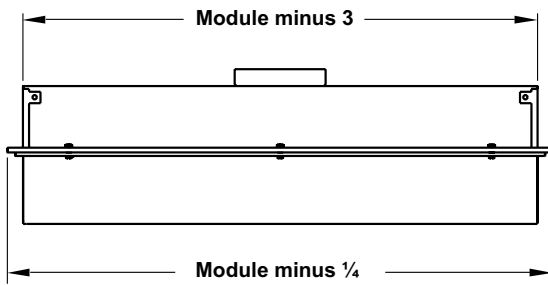

1-Way

Module Size	Nominal Inlet Size	A
24 x 24	8	7 7/8"
	10	9 7/8"
48 x 24	10	9 7/8"
	12	11 7/8"

Border Detail Lay-in

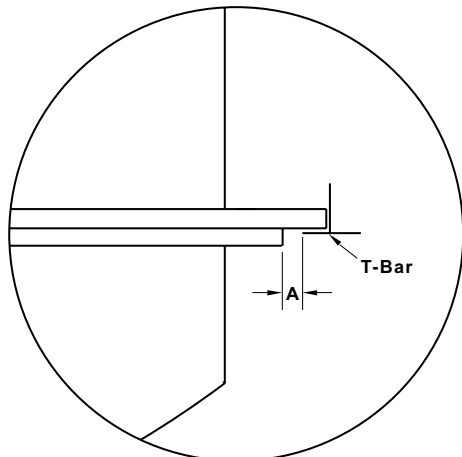

Tee	A
1"	3/8"
1 1/2"	1/8"

Surface Mounting with TRM frame

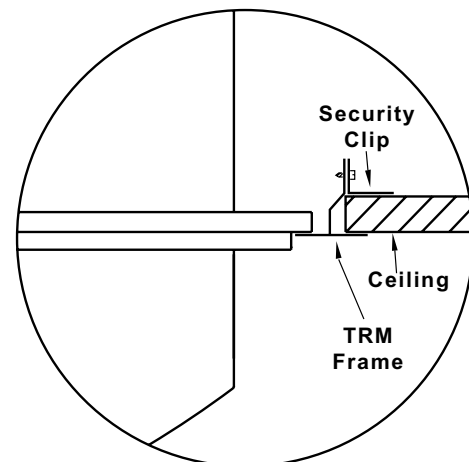

RADIATEC-AL AND RADIATEC-SS

Module Size Inlet Size	2-Way Pattern				Horizontal Spread (feet)						Vertical Throw (feet)					
					5 Degree ΔT			15 Degree ΔT			5 Degree ΔT			15 Degree ΔT		
	cfm	Ps	Pt	NC	100 - 75 - 50			100 - 75 - 50			100 - 75 - 50			100 - 75 - 50		
24" x 24" 8" Inlet	200	0.082	0.061	-	5	6	8	4	5	7	2	3	3	2	3	4
	300	0.092	0.138	18	7	8	9	6	7	8	2	4	5	2	4	6
	400	0.163	0.245	28	8	9	10	7	8	10	4	5	6	4	5	7
24" x 24" 10" Inlet	300	0.075	0.094	18	6	7	8	6	6	7	3	4	5	3	4	5
	400	0.133	0.167	28	6	7	9	6	7	8	4	5	6	4	5	6
	500	0.209	0.261	35	7	8	10	7	8	9	4	5	6	5	6	7
48" x 24" 10" Inlet	400	0.027	0.061	-	2	3	5	2	3	5	1	2	3	2	3	4
	600	0.062	0.138	15	4	5	6	4	5	6	1	2	4	3	4	6
	800	0.111	0.245	23	5	6	7	5	6	7	1	2	4	4	5	7
48" x 24" 12" Inlet	600	0.065	0.101	-	4	5	7	3	5	6	2	3	4	3	4	5
	800	0.114	0.179	20	5	6	8	4	5	7	3	4	5	4	5	6
	1000	0.179	0.280	27	6	7	9	5	6	8	3	4	6	4	5	7
Module Size Inlet Size	1-Way Pattern				Horizontal Spread (feet)						Vertical Throw (feet)					
					5 Degree ΔT			15 Degree ΔT			5 Degree ΔT			15 Degree ΔT		
	cfm	Ps	Pt	NC	100 - 75 - 50			100 - 75 - 50			100 - 75 - 50			100 - 75 - 50		
24" x 24" 8" Inlet	200	0.053	0.071	12	5	6	7	5	6	7	1	2	3	1	2	3
	300	0.118	0.164	25	6	7	8	6	7	9	2	4	6	2	4	6
	400	0.209	0.291	34	7	8	9	7	8	10	4	5	7	3	5	7
24" x 24" 10" Inlet	300	0.111	0.130	26	5	6	7	5	6	8	4	5	6	6	7	9
	400	0.196	0.230	35	6	7	8	6	7	9	5	6	7	7	8	10
	500	0.308	0.360	41	7	8	10	7	8	10	6	7	8	8	9	11
48" x 24" 10" Inlet	400	0.029	0.063	-	3	5	7	3	5	8	3	4	6	4	6	8
	600	0.066	0.142	16	5	6	8	6	7	9	5	6	7	6	7	8
	800	0.119	0.253	26	7	8	9	7	8	10	5	6	8	7	8	10
48" x 24" 12" Inlet	600	0.075	0.111	-	4	6	8	5	6	7	4	5	6	6	6	7
	800	0.133	0.198	23	7	8	9	6	7	8	5	6	7	7	8	10
	1000	0.208	0.309	31	8	9	11	7	8	9	5	6	7	8	9	11

- Spread is the maximum width of the isovel at the indicated terminal velocity
- Horizontal throw is the furthest distance from diffuser center point where the indicated terminal velocity can be measured
- Vertical throw is the furthest distance below the ceiling where the indicated terminal velocity can be measured
- Low emissivity heaters were used to maintain loads, which were set to match the supply air conditions. There were no obstructions in the room during the tests.
- Sound and pressure drop tests were conducted in accordance with ASHRAE Standard 70-2006 and ANSI S1.31 Procedures

2-WAY PATTERN

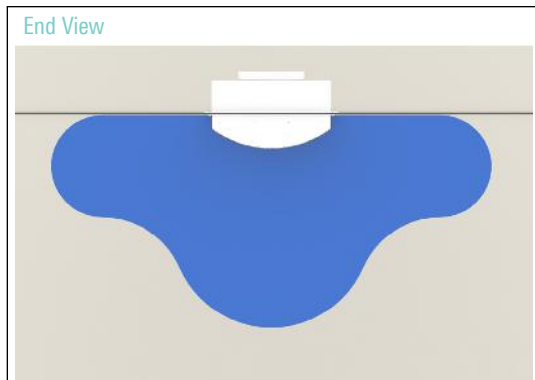

1-WAY PATTERN

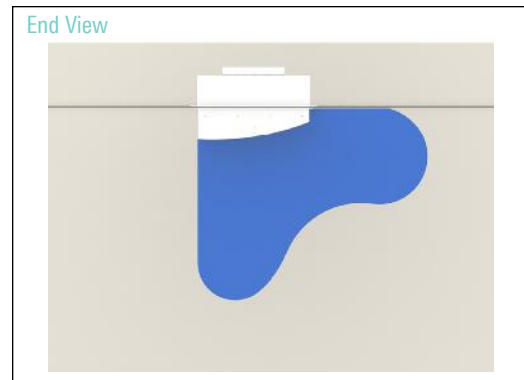

DIMENSIONS

Redefine your comfort zone.™ | www.titus-hvac.com

RADIATEC UNIT DIMENSIONS

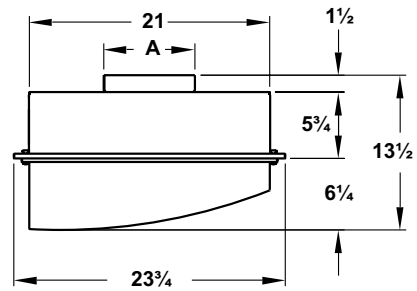
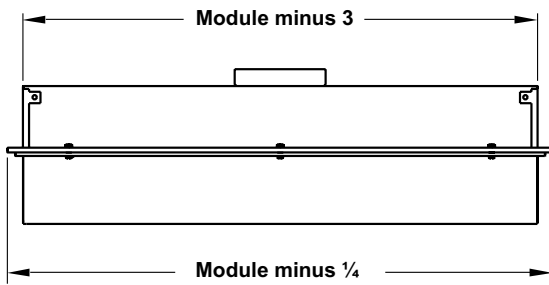
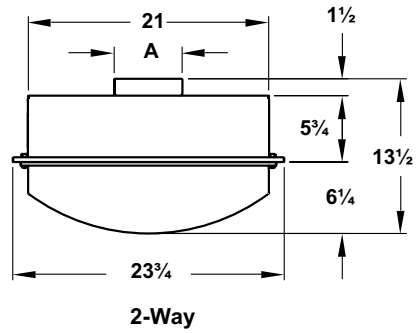
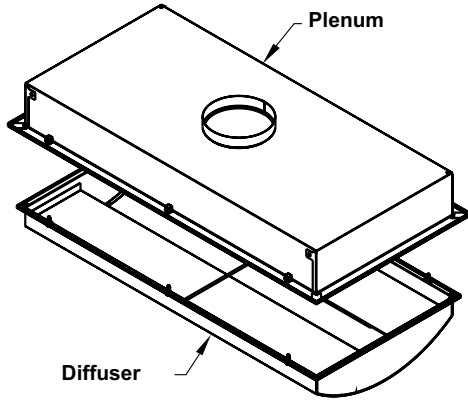

Module Size	Nominal Inlet Size	A
24 x 24	8	7 7/8"
	10	9 7/8"
48 x 24	10	9 7/8"
	12	11 7/8"

**1-Way**

Border Detail Lay-in

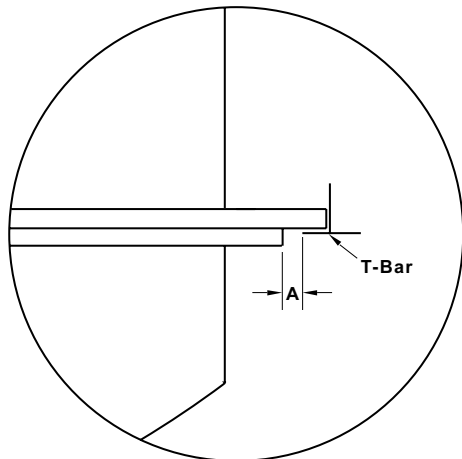

Tee	A
1"	3/8"
1 1/2"	1/8"

Surface Mounting with TRM frame

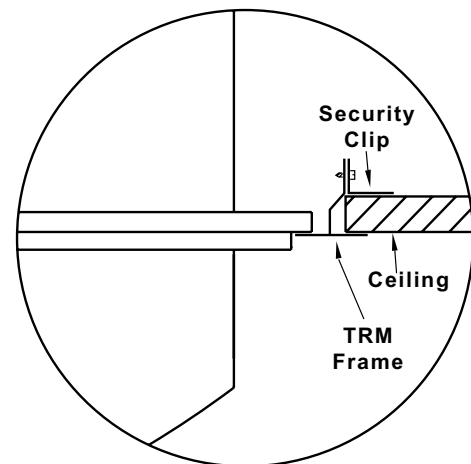

R

DIMENSIONS

RADIATEC-AL AND RADIATEC-SS

Module Size Inlet Size	2-Way Pattern				Horizontal Spread (feet)						Vertical Throw (feet)					
					5 Degree ΔT			15 Degree ΔT			5 Degree ΔT			15 Degree ΔT		
	cfm	Ps	Pt	NC	100 - 75 - 50			100 - 75 - 50			100 - 75 - 50			100 - 75 - 50		
24" x 24" 8" Inlet	200	0.082	0.061	-	5	6	8	4	5	7	2	3	3	2	3	4
	300	0.092	0.138	18	7	8	9	6	7	8	2	4	5	2	4	6
	400	0.163	0.245	28	8	9	10	7	8	10	4	5	6	4	5	7
24" x 24" 10" Inlet	300	0.075	0.094	18	6	7	8	6	6	7	3	4	5	3	4	5
	400	0.133	0.167	28	6	7	9	6	7	8	4	5	6	4	5	6
	500	0.209	0.261	35	7	8	10	7	8	9	4	5	6	5	6	7
48" x 24" 10" Inlet	400	0.027	0.061	-	2	3	5	2	3	5	1	2	3	2	3	4
	600	0.062	0.138	15	4	5	6	4	5	6	1	2	4	3	4	6
	800	0.111	0.245	23	5	6	7	5	6	7	1	2	4	4	5	7
48" x 24" 12" Inlet	600	0.065	0.101	-	4	5	7	3	5	6	2	3	4	3	4	5
	800	0.114	0.179	20	5	6	8	4	5	7	3	4	5	4	5	6
	1000	0.179	0.280	27	6	7	9	5	6	8	3	4	6	4	5	7
Module Size Inlet Size	1-Way Pattern				Horizontal Spread (feet)						Vertical Throw (feet)					
					5 Degree ΔT			15 Degree ΔT			5 Degree ΔT			15 Degree ΔT		
	cfm	Ps	Pt	NC	100 - 75 - 50			100 - 75 - 50			100 - 75 - 50			100 - 75 - 50		
24" x 24" 8" Inlet	200	0.053	0.071	12	5	6	7	5	6	7	1	2	3	1	2	3
	300	0.118	0.164	25	6	7	8	6	7	9	2	4	6	2	4	6
	400	0.209	0.291	34	7	8	9	7	8	10	4	5	7	3	5	7
24" x 24" 10" Inlet	300	0.111	0.130	26	5	6	7	5	6	8	4	5	6	6	7	9
	400	0.196	0.230	35	6	7	8	6	7	9	5	6	7	7	8	10
	500	0.308	0.360	41	7	8	10	7	8	10	6	7	8	8	9	11
48" x 24" 10" Inlet	400	0.029	0.063	-	3	5	7	3	5	8	3	4	6	4	6	8
	600	0.066	0.142	16	5	6	8	6	7	9	5	6	7	6	7	8
	800	0.119	0.253	26	7	8	9	7	8	10	5	6	8	7	8	10
48" x 24" 12" Inlet	600	0.075	0.111	-	4	6	8	5	6	7	4	5	6	6	6	7
	800	0.133	0.198	23	7	8	9	6	7	8	5	6	7	7	8	10
	1000	0.208	0.309	31	8	9	11	7	8	9	5	6	7	8	9	11

- Spread is the maximum width of the isovel at the indicated terminal velocity
- Horizontal throw is the furthest distance from diffuser center point where the indicated terminal velocity can be measured
- Vertical throw is the furthest distance below the ceiling where the indicated terminal velocity can be measured
- Low emissivity heaters were used to maintain loads, which were set to match the supply air conditions. There were no obstructions in the room during the tests.
- Sound and pressure drop tests were conducted in accordance with ASHRAE Standard 70-2006 and ANSI S1.31 Procedures

2-WAY PATTERN

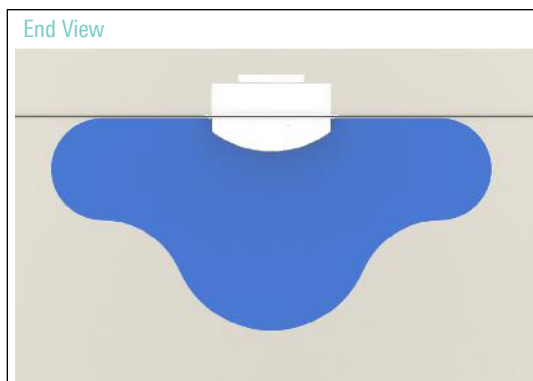

1-WAY PATTERN

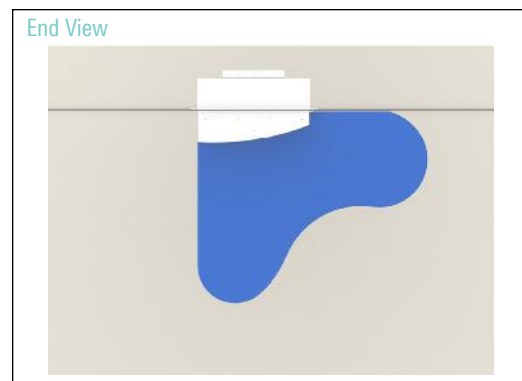



## Horizontal Pattern

## critical environment diffusers

### TDCR

- Ideal for installation in laboratory spaces and anterooms
- Snap-in, tool-less filter installation and removal
- Factory pressure tested
- Fully welded construction option
- Roomside accessible PAO challenge port option
- Louvered face quickly removes by loosening quarter-turn fasteners
- Retainer cables prevent the perforated face from falling after removal
- 4-way cross-flow air flow pattern
- Accommodates filters with 2", 3", & 4" media packs
- Compatible with 1" or 1½" T-bar ceiling grids
- Optional TRM mounting frame available for surface mounting

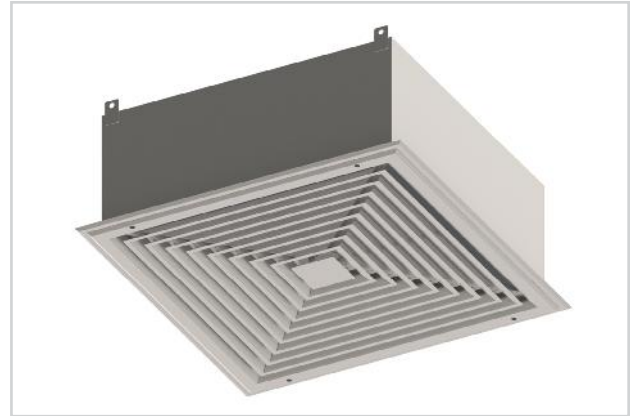

TDCR

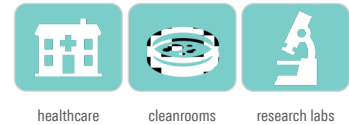

 See website for Specifications

### MODELS:

TDCR-AL / Aluminum Face with Aluminum Backpan  
TDCR-SS / 304 Stainless Steel Face and Backpan

### FINISHES:

Standard Finish - #26 White and #04 Mill  
Optional Finish - #84 Black

### OVERVIEW

Ultra Clean, High Volume, Louvered Face, Cross Flow Air Diffusion Technology

TDCR models are designed to allow large volumes of filtered air to be supplied to the space in a 4-way cross-flow air pattern. Titus Series TDCR diffusers handle an unusually large amount of filtered air for a given pressure drop and noise level. Including snap-in, auto-centering filter retainers, the TDCR reduces the amount of time and effort during installation and removal of filters. This decreases the time a laboratory or anteroom is out of commission.

Applications include anterooms for pharmaceutical manufacturing, biotechnology research and many other applications where an elevated volume of clean airflow is required to purge contaminants from the space in a short duration, preventing the migration of airborne particles into or out of an isolated space. The horizontal throw pattern combined with the high volume of filtered air that can be supplied by the TDCR also make them ideal for use in laboratories with high heat loads. These diffusers are an excellent choice for ISO Class 9 to 7 spaces.

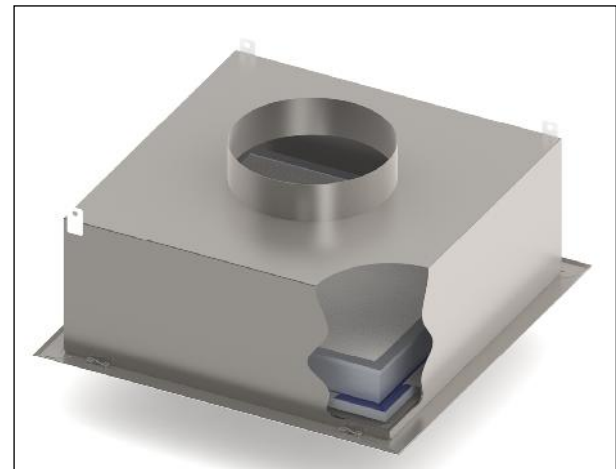

Cross section view of the TDCR

TDCR UNIT DIMENSIONS

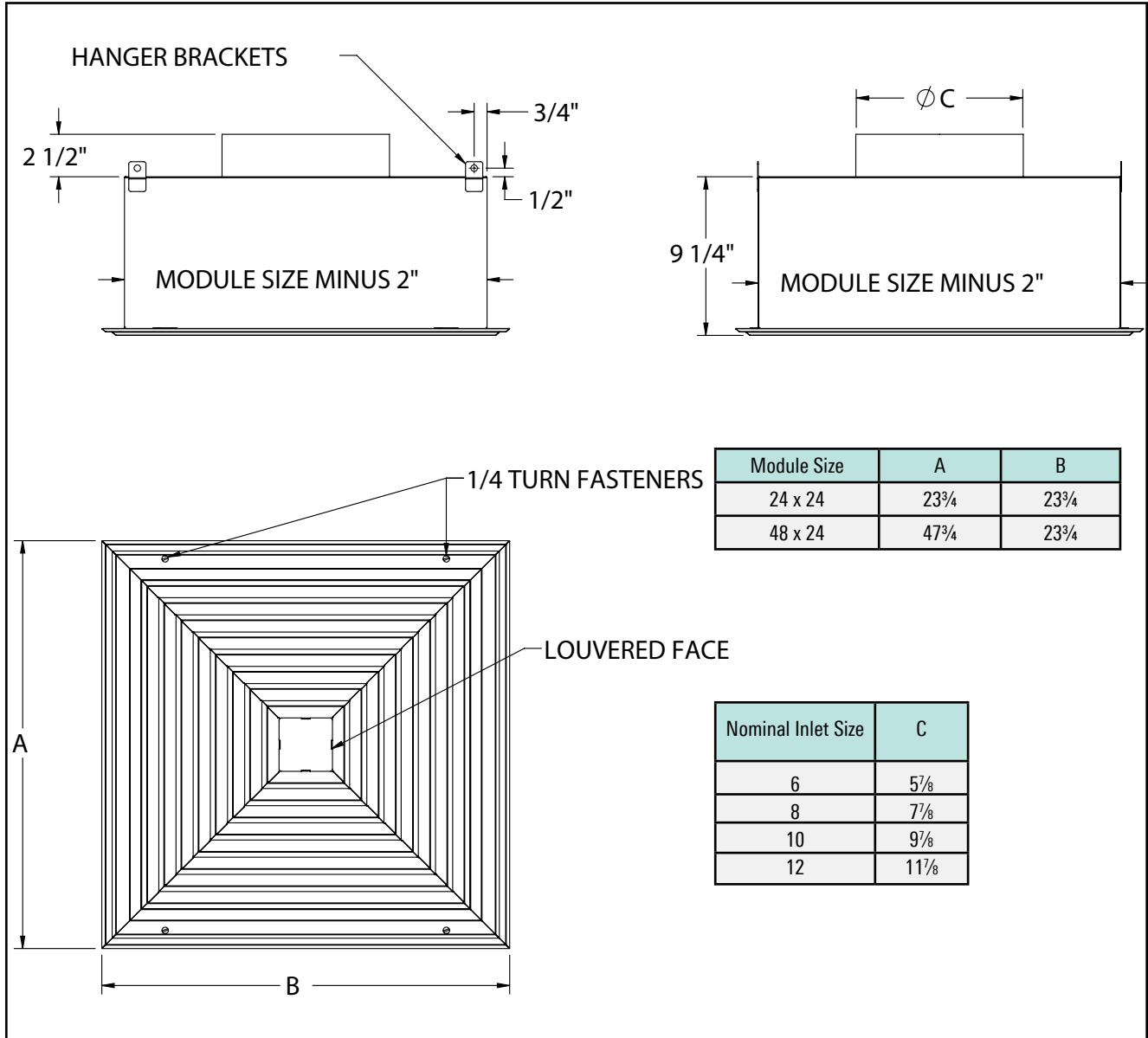

OPTIONAL ACCESSORIES

Cable Operated Damper Detail

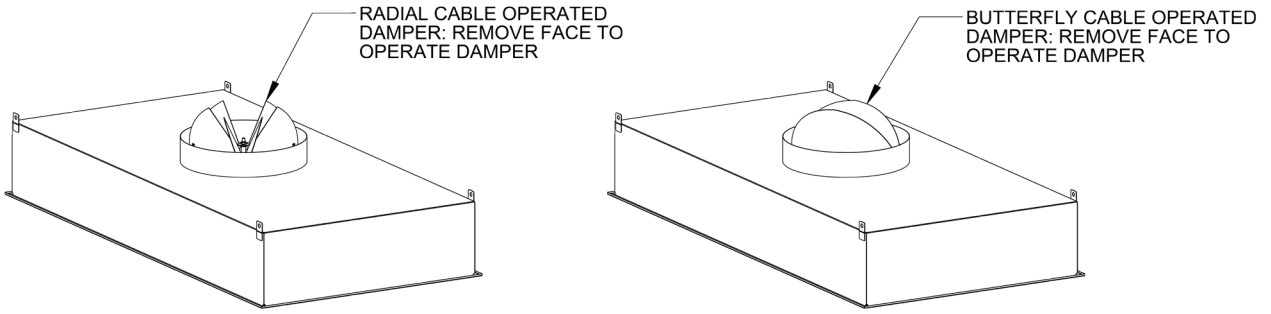

Port & Cable Operator Details

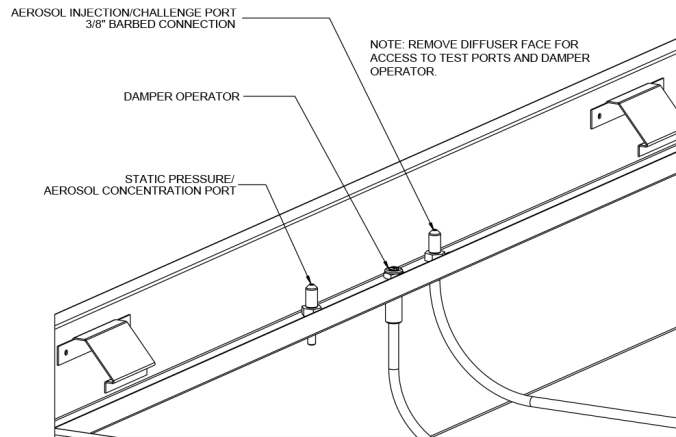

Aerosol Manifold Details

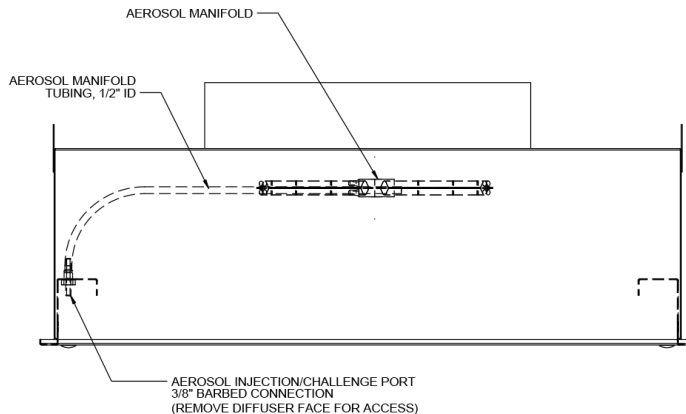

OPTIONAL ACCESSORIES

Knife Edge/Gel Seal Detail

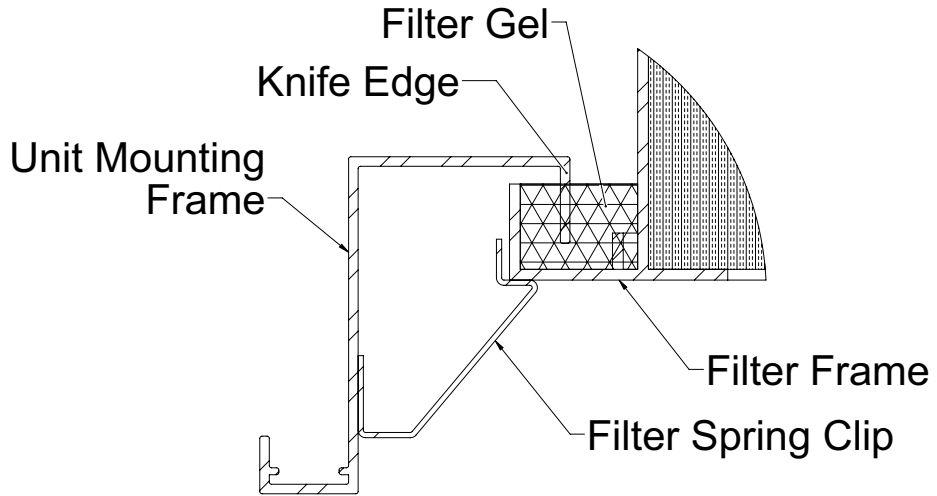

TDCR PERFORMANCE DATA

TDCR with HEPA-R Filter - 24" x 24" with 10" round inlet

Air Flow, CFM	100	125	150	175	200	225	250	300	350
Static Pressure	0.19	0.24	0.29	0.34	0.40	0.45	0.51	0.62	0.74
Total Pressure	0.19	0.24	0.29	0.35	0.41	0.46	0.52	0.64	0.77
NC (Noise Criterion)	-	-	11	13	15	17	19	21	24
Throw	1-2-4	1-2-5	2-3-6	2-3-6	3-4-7	3-4-7	3-5-8	4-6-9	4-6-9

TDCR with HEPA-R Filter - 48" x 24" with 12" round inlet

Air Flow, CFM	250	300	350	400	450	500	550	600	650
Static Pressure	0.22	0.27	0.32	0.38	0.43	0.49	0.55	0.61	0.67
Total Pressure	0.23	0.28	0.33	0.40	0.45	0.52	0.58	0.65	0.71
NC (Noise Criterion)	13	17	21	24	27	29	31	34	35
Throw (short side)	1-2-4	1-3-5	2-3-5	2-4-5	3-4-6	3-4-6	4-4-6	4-5-6	4-5-7
Throw (long side)	1-2-7	1-3-10	2-3-12	2-4-14	3-6-14	3-7-15	4-8-16	4-10-17	5-11-17

PERFORMANCE NOTES

- Throw values are given for terminal velocities of 150, 100, and 50 fpm. For an explanation of catalog throw data, see the section, Engineering Guidelines for catalog throw data.
- Throw data is based on isothermal conditions
- Static pressure and total pressure values include initial resistance of a HEPA-R filter with 2 inch thick media pack.
- NC values are based on a room absorption of 10 dB, re 10-12 watts, with one diffuser operating
- NC values less than 10 is shown as "-"
- These products have been tested per ANSI/ASHRAE 70-2006. Actual performance, with flexible duct inlet, may vary in the field. See the section, Engineering Guidelines for additional information.
- Data in the tables apply when the diffuser is mounted nearly flush with the ceiling for maximum ceiling effect. When no ceiling effect is present, the horizontal throw will be about 25% less than shown in the tables. The mounting distance below the ceiling will also affect the downward projection.

## Laminar Pattern

## critical environment diffusers

### TLF

- Ideal for installation in hospital operating rooms
- Perforated face quickly removes by loosening quarter-turn fasteners
- Retainer cables prevent the perforated face from falling after removal
- Internal baffles to distribute air evenly over perforated face
- Perforated face with  $\frac{3}{32}$ " diameter holes on  $\frac{1}{4}$ " centers in a 60° staggered pattern
- Compatible with 1" or 1½" T-bar ceiling grids
- Optional TRM mounting frame available for surface mounting



TLF



hospitals

surgical

cleanrooms

research labs

### MODELS:

TLF / Steel  
TLF-AA / Aluminum  
TLF-SS / 304 Stainless Steel

### FINISHES:

Standard Finish - #26 White  
Optional Finish - #04 Mill

### OVERVIEW

#### Vertical Laminar Flow Technology

TLF laminar flow diffusers are the industry standard for unidirectional flow. When unidirectional flow is desired, typically in areas classified as ISO 1 to 5, TLF is the choice.

TLF diffusers can be used to create clean zones by positioning the diffuser directly over the area to be washed with clean air. Clean zones are typically used as process areas within a cleanroom.

TLF diffusers are also used in most operating rooms as the center diffuser and many times these diffusers are surrounded by a linear air curtain. The vertical piston of air created by the TLF is used to discharge clean air over the patient during surgery or surgical procedures.

Unidirectional flow minimizes air induction, reducing the opportunity for contaminated air to be re-entrained and pollute a clean airstream.

 See website for Specifications

The TLF Series of laminar flow diffusers generates a low velocity, evenly distributed, downward moving "piston" of conditioned air.

Installed over the operating table in a hospital operating room, TLF diffusers help protect the patient from contaminated room secondary air. The only appreciable amount of room air entrainment occurs at the boundaries of the moving air mass, outside the confines of the operating table. As a result, the patient is effectively isolated from residual room air.

TLF is especially effective in cooling areas with heavy, localized, internal loads, as in computer rooms. The column of air delivered by the TLF cools the load source directly without generating high velocities in the occupied space.

R

TLF

TLF UNIT DIMENSIONS

Neck Size D	Inlet Height B
5, 6, 7, 8, 10, 12	2"

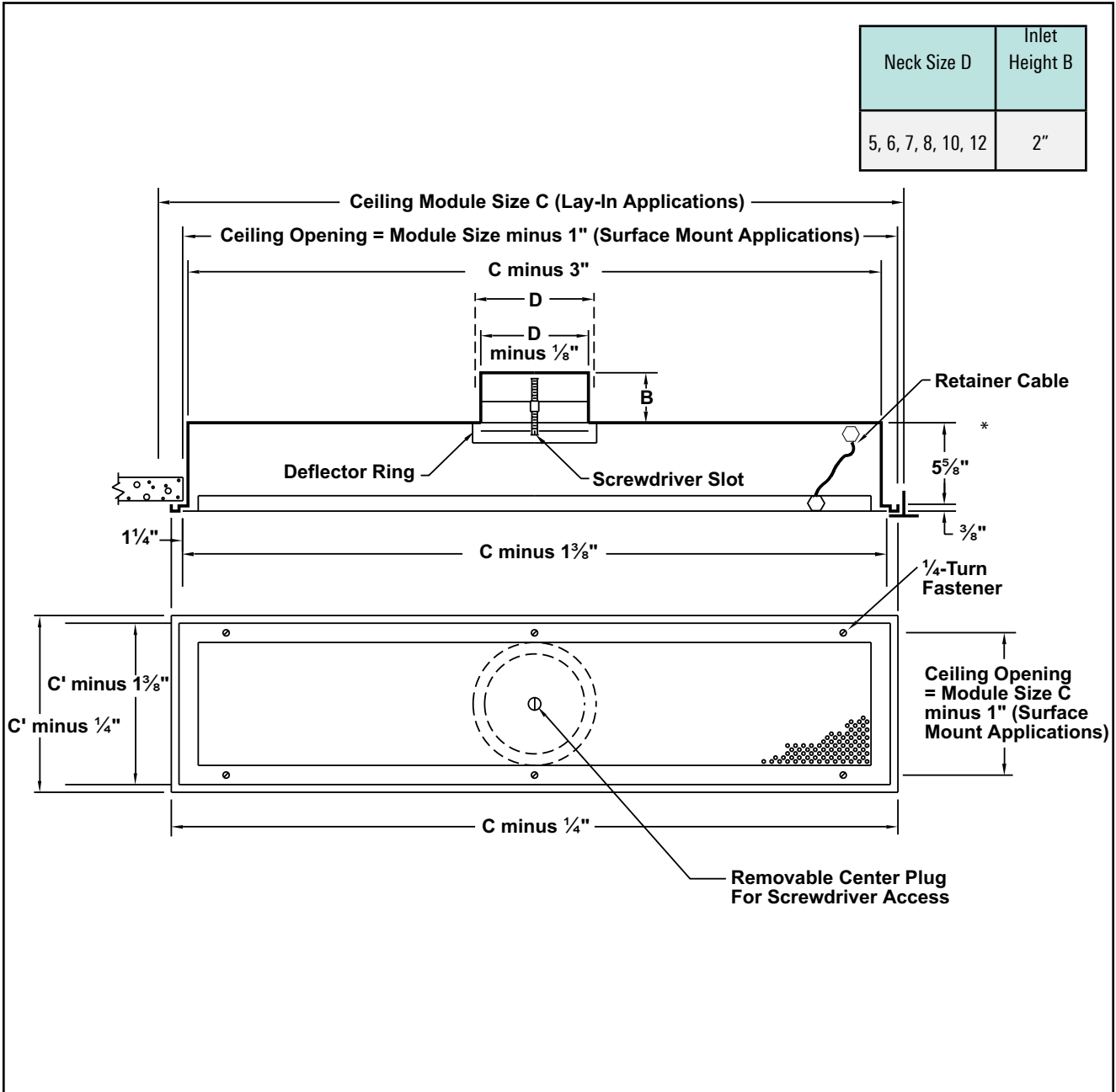

R



TLF, TLF-AA AND TLF-SS

7" Round Inlet	Airflow (CFM)	100	120	140	160	180	220	240	260	300
48" x 12" Module	Total Pressure	0.035	0.050	0.068	0.090	0.114	0.170	0.200	0.235	0.313
	NC (Noise Criteria)	11	16	20	24	28	34	37	40	44
60" x 12" Module	Total Pressure	0.035	0.050	0.068	0.090	0.114	0.170	0.200	0.235	0.313
	NC (Noise Criteria)	11	16	20	24	28	34	37	40	44
72" x 12" Module	Total Pressure	0.035	0.050	0.068	0.090	0.114	0.170	0.200	0.235	0.313
	NC (Noise Criteria)	11	16	20	24	28	34	36	39	43
24" x 24" Module	Total Pressure	0.035	0.050	0.068	0.090	0.114	0.170	0.200	0.235	0.313
	NC (Noise Criteria)	11	16	20	24	28	34	37	40	44
36" x 24" Module	Total Pressure	0.035	0.050	0.068	0.090	0.114	0.170	0.200	0.235	0.313
	NC (Noise Criteria)	11	16	20	24	28	34	37	40	44
48" x 24" Module	Total Pressure	0.035	0.050	0.068	0.090	0.114	0.170	0.200	0.235	0.313
	NC (Noise Criteria)	11	16	20	24	28	33	36	39	43

8" Round Inlet	Airflow (CFM)	100	120	140	160	180	220	240	260	300
48" x 24" Module	Total Pressure	0.020	0.027	0.038	0.050	0.062	0.090	0.113	0.130	0.175
	NC (Noise Criteria)	-	-	14	18	22	28	31	33	37
60" x 24" Module	Total Pressure	0.020	0.027	0.038	0.049	0.061	0.089	0.109	0.126	0.168
	NC (Noise Criteria)	-	-	14	18	22	28	31	33	37
72" x 24" Module	Total Pressure	0.019	0.027	0.037	0.048	0.060	0.088	0.105	0.124	0.162
	NC (Noise Criteria)	-	-	14	18	22	28	31	33	37

10" Round Inlet	Airflow (CFM)	215	240	265	295	320	345	400	425	515
48" x 24" Module	Total Pressure	0.043	0.053	0.065	0.080	0.094	0.110	0.147	0.166	0.244
	NC (Noise Criteria)	19	22	25	28	31	33	38	40	45
60" x 24" Module	Total Pressure	0.043	0.053	0.065	0.079	0.094	0.110	0.147	0.166	0.244
	NC (Noise Criteria)	19	22	25	28	31	33	38	40	45
72" x 24" Module	Total Pressure	0.042	0.052	0.063	0.079	0.092	0.107	0.145	0.163	0.240
	NC (Noise Criteria)	19	22	25	28	31	33	38	40	45

12" Round Inlet	Airflow (CFM)	215	240	265	295	320	345	400	425	515
48" x 24" Module	Total Pressure	0.023	0.029	0.035	0.043	0.051	0.059	0.080	0.090	0.132
	NC (Noise Criteria)	11	15	18	22	24	27	32	34	40
60" x 24" Module	Total Pressure	0.023	0.029	0.035	0.043	0.051	0.059	0.080	0.090	0.132
	NC (Noise Criteria)	11	15	18	22	24	27	32	34	40
72" x 24" Module	Total Pressure	0.023	0.028	0.034	0.042	0.050	0.058	0.078	0.088	0.129
	NC (Noise Criteria)	11	15	18	22	24	27	32	34	40

- All data based on full open disc position
- NC values are based on a room absorption of 10 dB.
- Data obtained in accordance with ASHRAE Standard 70-2006 and ASHRAE Standard 113-2013
- See the section, Engineering Guidelines and the topic 'Procedure to Obtain Catalog Throw Data' in this catalog for throw information
- Performance data for additional sizes not shown can be obtained by using the Titus TEAMS program

## TLF-LED

- Ideal for installation in hospital operating rooms
- Integral LED luminaire with tunable color temperature @ 90 CRI
- Roomside accessible control enclosure
- Perforated face quickly removes by loosening quarter-turn fasteners
- Retainer cables prevent the perforated face from falling after removal
- Internal baffles to distribute air evenly over perforated face
- Compatible with 1" or 1½" T-bar ceiling grids

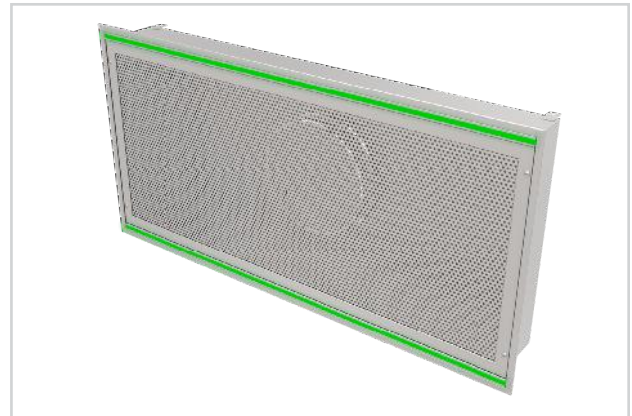

TLF-LED



hospitals

surgical

cleanrooms

research labs

### MODELS:

TLF-AA-LED / Aluminum  
TLF-SS-LED / 304 Stainless Steel

### FINISHES:

Standard Finish - #26 White  
Optional Finish - #04 Mill

### OVERVIEW

#### Vertical Laminar Flow Technology

TLF-LED laminar flow diffusers are the industry standard for unidirectional flow. When unidirectional flow is desired, typically in areas classified as ISO 1 to 5, TLF-LED is the choice.

TLF-LED diffusers can be used to create clean zones by positioning the diffuser directly over the area to be washed with clean air. Clean zones are typically used as process areas within a cleanroom.

TLF-LED diffusers are also used in most operating rooms as the center diffuser and many times these diffusers are surrounded by a linear air curtain. The vertical piston of air created by the TLF-LED is used to discharge clean air over the patient during surgery or surgical procedures.

 See website for Specifications

The integration of high-output, high-efficiency LED lighting eliminates the need for specialized luminaires around the perimeter of the diffuser array. The integrated LED lighting improves lighting quality over the operating table or workspace with more direct lighting and less shadows. Eliminating the need for the perimeter lighting reduces installed components, enabling more flexibility for placement of diffusers and ceiling mounted equipment.

Unidirectional flow minimizes air induction, reducing the opportunity for contaminated air to be re-entrained and pollute a clean airstream.

The TLF-LED Series of laminar flow diffusers generates a low velocity, evenly distributed, downward moving "piston" of conditioned air.

Installed over the operating table in a hospital operating room, TLF-LED diffusers help protect the patient from contaminated room secondary air. The only appreciable amount of room air entrainment occurs at the boundaries of the moving air mass, outside the confines of the operating table. As a result, the patient is effectively isolated from residual room air.

TLF-LED is especially effective in cooling areas with heavy, localized, internal loads, as in computer rooms. The column of air delivered by the TLF-LED cools the load source directly without generating high velocities in the occupied space.

TLF-LED UNIT DIMENSIONS

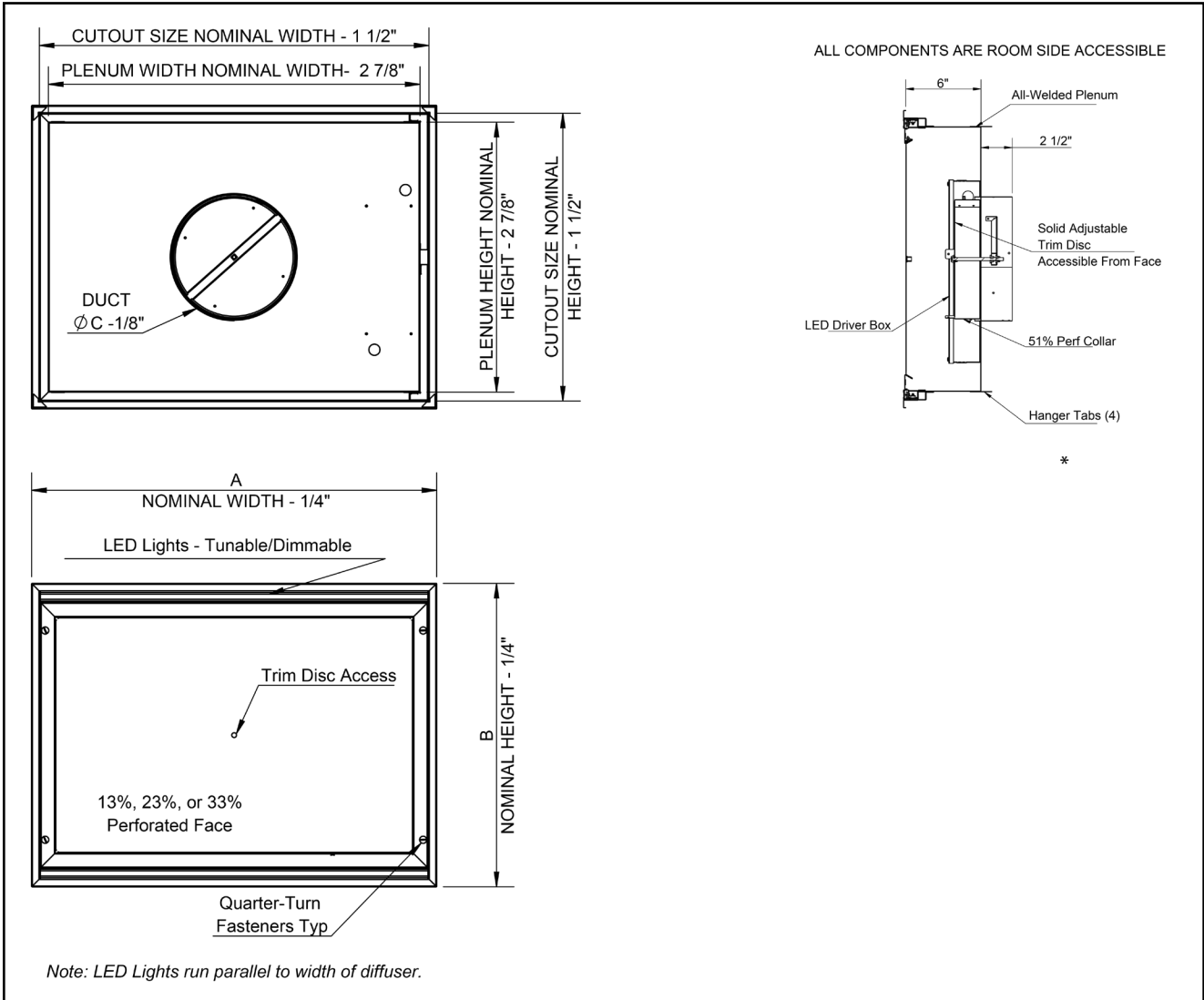

Module Size	A	B
24 x 12	23 <sup>3</sup> / <sub>4</sub>	11 <sup>3</sup> / <sub>4</sub>
24 x 24	23 <sup>3</sup> / <sub>4</sub>	23 <sup>3</sup> / <sub>4</sub>
36 x 12	35 <sup>3</sup> / <sub>4</sub>	11 <sup>3</sup> / <sub>4</sub>
48 x 12	47 <sup>3</sup> / <sub>4</sub>	11 <sup>3</sup> / <sub>4</sub>
48 x 24	47 <sup>3</sup> / <sub>4</sub>	23 <sup>3</sup> / <sub>4</sub>
60 x 12	59 <sup>3</sup> / <sub>4</sub>	11 <sup>3</sup> / <sub>4</sub>
60 x 24	59 <sup>3</sup> / <sub>4</sub>	23 <sup>3</sup> / <sub>4</sub>

Nominal Inlet Size	C
6	5 <sup>7</sup> / <sub>8</sub>
8	7 <sup>7</sup> / <sub>8</sub>
10	9 <sup>7</sup> / <sub>8</sub>
12	11 <sup>7</sup> / <sub>8</sub>

UNIT WIRING

Unit Wiring

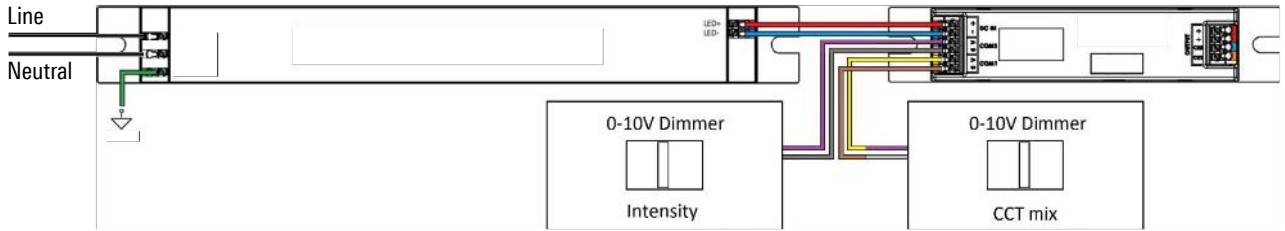

Note: Dimmers to be provided by others. Tunable White and Tunable Green to White configurations require dimmers for both intensity and color temperature.

Integrated LED Detail

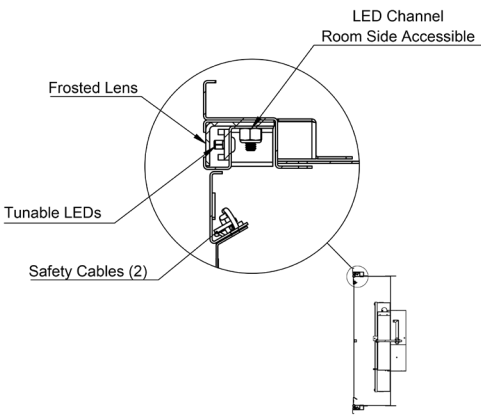

Control Enclosure Access

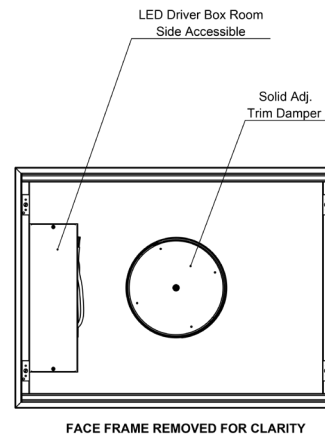

TLF-AA-LED AND TLF-SS-LED

7" Round Inlet	Airflow (CFM)	100	120	140	160	180	220	240	260	300
48" x 12" Module	Total Pressure	0.035	0.050	0.068	0.090	0.114	0.170	0.200	0.235	0.313
	NC (Noise Criteria)	11	16	20	24	28	34	37	40	44
60" x 12" Module	Total Pressure	0.035	0.050	0.068	0.090	0.114	0.170	0.200	0.235	0.313
	NC (Noise Criteria)	11	16	20	24	28	34	37	40	44
24" x 24" Module	Total Pressure	0.035	0.050	0.068	0.090	0.114	0.170	0.200	0.235	0.313
	NC (Noise Criteria)	11	16	20	24	28	34	37	40	44
48" x 24" Module	Total Pressure	0.035	0.050	0.068	0.090	0.114	0.170	0.200	0.235	0.313
	NC (Noise Criteria)	11	16	20	24	28	33	36	39	43

8" Round Inlet	Airflow (CFM)	100	120	140	160	180	220	240	260	300
48" x 24" Module	Total Pressure	0.020	0.027	0.038	0.050	0.062	0.090	0.113	0.130	0.175
	NC (Noise Criteria)	-	-	14	18	22	28	31	33	37
60" x 24" Module	Total Pressure	0.020	0.027	0.038	0.049	0.061	0.089	0.109	0.126	0.168
	NC (Noise Criteria)	-	-	14	18	22	28	31	33	37

10" Round Inlet	Airflow (CFM)	215	240	265	295	320	345	400	425	515
48" x 24" Module	Total Pressure	0.043	0.053	0.065	0.080	0.094	0.110	0.147	0.166	0.244
	NC (Noise Criteria)	19	22	25	28	31	33	38	40	45
60" x 24" Module	Total Pressure	0.043	0.053	0.065	0.079	0.094	0.110	0.147	0.166	0.244
	NC (Noise Criteria)	19	22	25	28	31	33	38	40	45

12" Round Inlet	Airflow (CFM)	215	240	265	295	320	345	400	425	515
48" x 24" Module	Total Pressure	0.023	0.029	0.035	0.043	0.051	0.059	0.080	0.090	0.132
	NC (Noise Criteria)	11	15	18	22	24	27	32	34	40
60" x 24" Module	Total Pressure	0.023	0.029	0.035	0.043	0.051	0.059	0.080	0.090	0.132
	NC (Noise Criteria)	11	15	18	22	24	27	32	34	40

- All data based on full open disc position
- NC values are based on a room absorption of 10 dB.
- Data obtained in accordance with ASHRAE Standard 70-2006 and ASHRAE Standard 113-2013
- See the section, Engineering Guidelines and the topic 'Procedure to Obtain Catalog Throw Data' in this catalog for throw information

## TLFR

- Ideal for installation in hospital operating rooms
- Snap-in, tool-less HEPA filter installation and removal
- Factory pressure tested
- Fully welded construction option
- Roomside accessible PAO challenge port option
- Perforated face quickly removes by loosening quarter-turn fasteners
- Retainer cables prevent the perforated face from falling after removal
- Three free area options
- Accommodates filters with 2", 3", & 4" media packs
- Compatible with 1" or 1½" T-bar ceiling grids
- Optional TRM mounting frame available for surface mounting

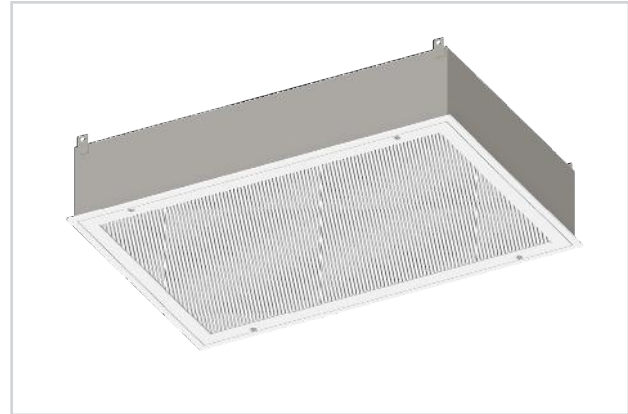

TLFR



hospitals

surgical

cleanrooms

research labs



See website for Specifications

### MODELS:

TLFR-AA / Aluminum  
TLFR-SS / 304 Stainless Steel

### FINISHES:

Standard Finish - #26 White  
Optional Finish - #04 Mill

### OVERVIEW

#### Vertical Laminar Flow Technology

The next generation Titus unidirectional flow diffuser for critical environments has been designed to comply with industry standard, ASHRAE 170, offering important safeguards for surgical patients. Used in operating rooms as the primary diffusers, the vertical piston of air created by the TLFR is used to discharge clean air over the patient during operations. Including snap-in, autocentering filter retainers, the new TLFR reduces the amount of time and effort during installation and removal of filters. This decreases the time a lab or operating suite is out of commission, allowing facilities to maximize profitability and patient care.

Unidirectional flow minimizes air induction, reducing the opportunity for contaminated air to be re-entrained and pollute a clean airstream.

The TLFR Series of laminar flow diffusers generates a low velocity, evenly distributed, downward moving "piston" of conditioned air.

Installed over the operating table in a hospital operating room, TLFR diffusers help protect the patient from contaminated room secondary air. The only appreciable amount of room air entrainment occurs at the boundaries of the moving air mass, outside the confines of the operating table. As a result, the patient is effectively isolated from residual room air.

TLFR is especially effective in cooling areas with heavy, localized, internal loads, as in computer rooms. The column of air delivered by the TLFR cools the load source directly without generating high velocities in the occupied space.

TLFR UNIT DIMENSIONS

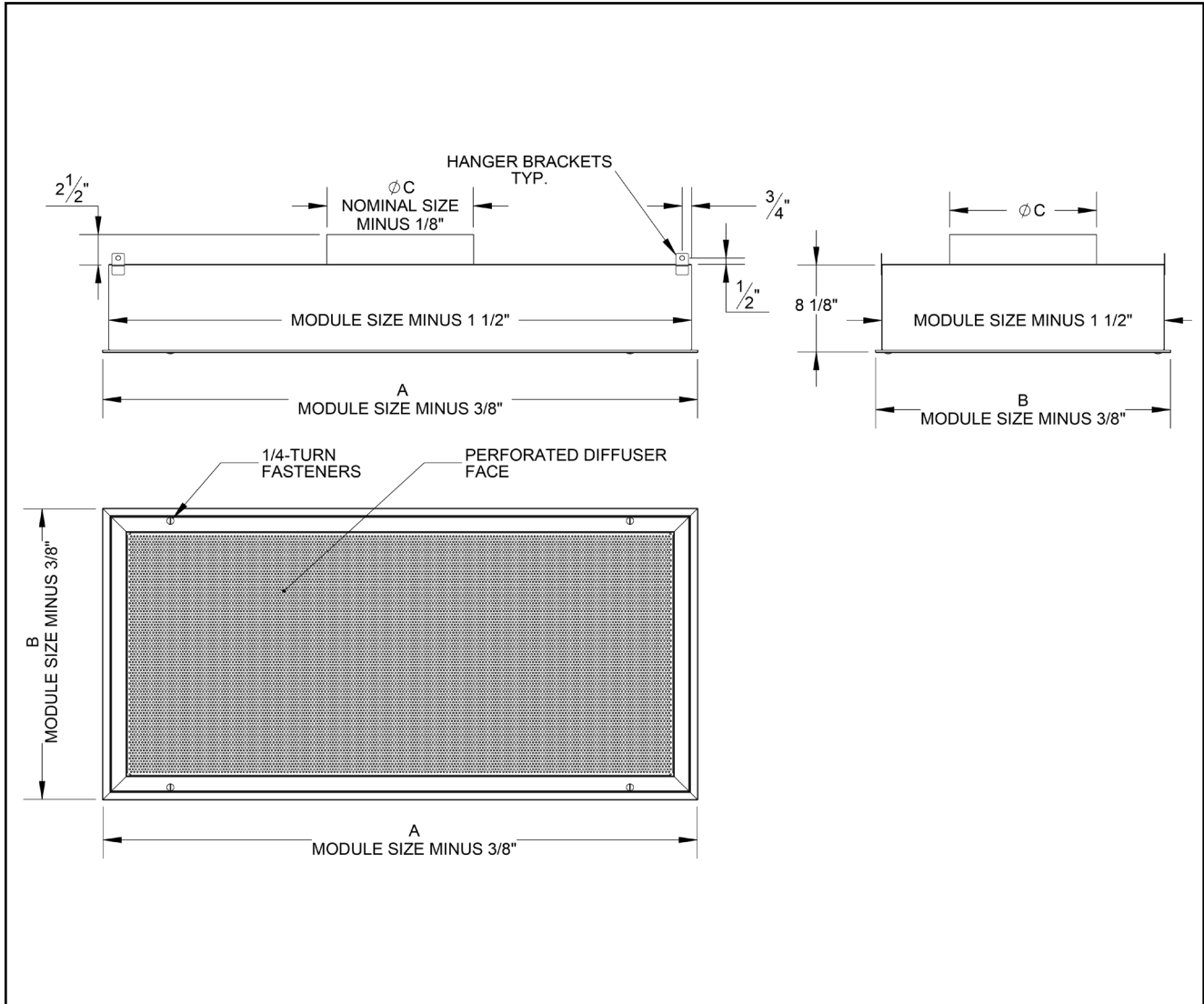

Module Size	A	B
24 x 12	23 <sup>5</sup> / <sub>8</sub> "	11 <sup>5</sup> / <sub>8</sub> "
24 x 24	23 <sup>5</sup> / <sub>8</sub> "	23 <sup>5</sup> / <sub>8</sub> "
36 x 12	35 <sup>5</sup> / <sub>8</sub> "	11 <sup>5</sup> / <sub>8</sub> "
36 x 24	35 <sup>5</sup> / <sub>8</sub> "	23 <sup>5</sup> / <sub>8</sub> "
48 x 12	47 <sup>5</sup> / <sub>8</sub> "	11 <sup>5</sup> / <sub>8</sub> "
48 x 24	47 <sup>5</sup> / <sub>8</sub> "	23 <sup>5</sup> / <sub>8</sub> "
48 x 36	47 <sup>5</sup> / <sub>8</sub> "	35 <sup>5</sup> / <sub>8</sub> "
60 x 12	59 <sup>5</sup> / <sub>8</sub> "	11 <sup>5</sup> / <sub>8</sub> "
60 x 24	59 <sup>5</sup> / <sub>8</sub> "	23 <sup>5</sup> / <sub>8</sub> "
60 x 36	59 <sup>5</sup> / <sub>8</sub> "	35 <sup>5</sup> / <sub>8</sub> "
72 x 12	71 <sup>5</sup> / <sub>8</sub> "	11 <sup>5</sup> / <sub>8</sub> "
72 x 24	71 <sup>5</sup> / <sub>8</sub> "	23 <sup>5</sup> / <sub>8</sub> "
72 x 36	71 <sup>5</sup> / <sub>8</sub> "	35 <sup>5</sup> / <sub>8</sub> "

Nominal Inlet Size	C
6	5 <sup>7</sup> / <sub>8</sub> "
8	7 <sup>7</sup> / <sub>8</sub> "
10	9 <sup>7</sup> / <sub>8</sub> "
12	11 <sup>7</sup> / <sub>8</sub> "

OPTIONAL ACCESSORIES

Cable Operated Damper Detail

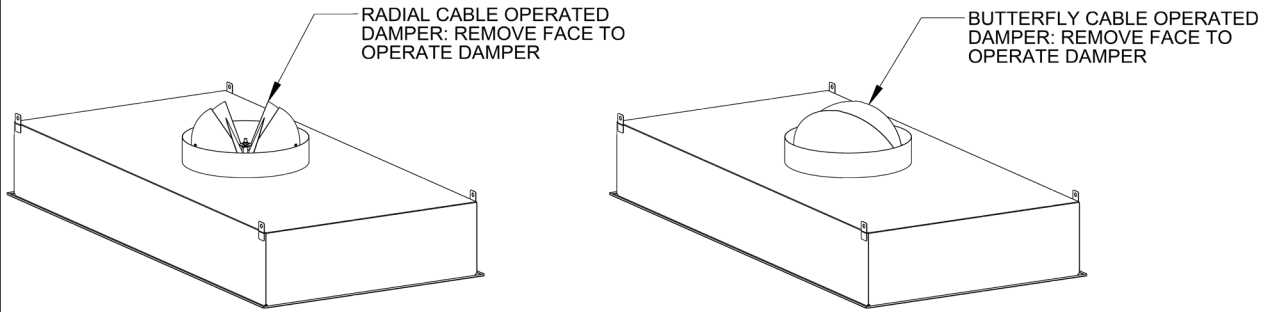

Port & Cable Operator Details

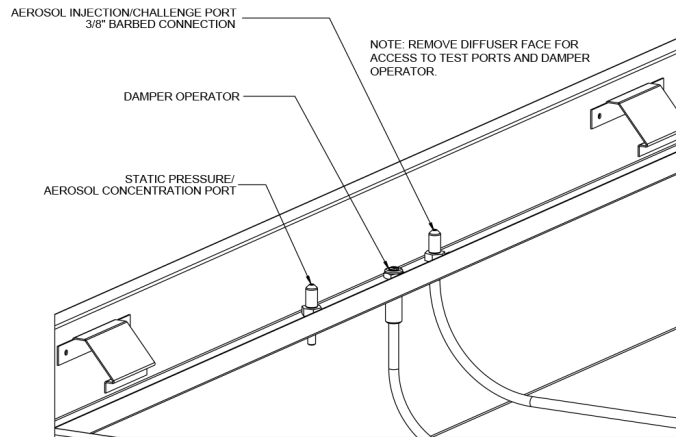

Aerosol Manifold Details

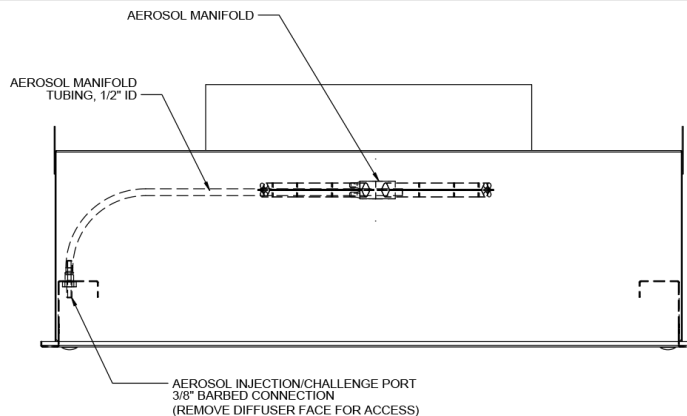



OPTIONAL ACCESSORIES

Knife Edge/Gel Seal Detail

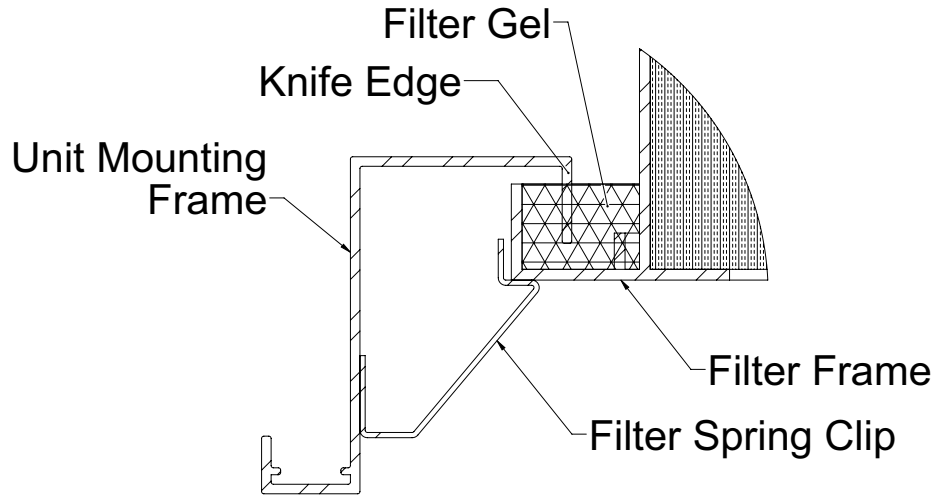

TLFR-AA / TLFR-SS WITH 13% PERFORATED FACE - 2" FILTER

6" Round Inlet	Airflow (CFM)	100	120	140	160	180	220	240	260	300
48" x 12" Module	Total Pressure	0.306	0.376	0.448	0.524	0.602	0.767	0.854	0.944	1.132
	NC (Noise Criteria)	-	-	-	-	23	30	33	36	41
24" x 24" Module	Total Pressure	0.243	0.299	0.359	0.421	0.487	0.625	0.698	0.775	0.936
	NC (Noise Criteria)	-	-	-	-	23	30	33	36	41
24" x 36" Module	Total Pressure	0.154	0.192	0.233	0.276	0.321	0.418	0.471	0.526	0.643
	NC (Noise Criteria)	-	-	-	-	23	30	33	36	41
24" x 48" Module	Total Pressure	0.117	0.147	0.180	0.215	0.251	0.333	0.377	0.423	0.522
	NC (Noise Criteria)	-	-	-	-	23	30	33	36	41

8" Round Inlet	Airflow (CFM)	100	120	140	160	180	220	240	260	300
60" x 12" Module	Total Pressure	0.224	0.272	0.321	0.372	0.423	0.529	0.584	0.640	0.755
	NC (Noise Criteria)	-	-	-	-	-	-	-	-	21
72" x 12" Module	Total Pressure	0.184	0.224	0.264	0.305	0.349	0.436	0.482	0.528	0.625
	NC (Noise Criteria)	-	-	-	-	-	-	-	-	21
48" x 24" Module	Total Pressure	0.099	0.121	0.144	0.168	0.192	0.244	0.271	0.298	0.357
	NC (Noise Criteria)	-	-	-	-	-	-	-	-	21
24" x 60" Module	Total Pressure	0.078	0.097	0.114	0.134	0.154	0.197	0.219	0.243	0.292
	NC (Noise Criteria)	-	-	-	-	-	-	-	-	21
24" x 72" Module	Total Pressure	0.065	0.081	0.097	0.113	0.130	0.168	0.187	0.207	0.250
	NC (Noise Criteria)	-	-	-	-	-	-	-	-	21

10" Round Inlet	Airflow (CFM)	215	240	265	295	320	345	400	425	515
48" x 24" Module	Total Pressure	0.214	0.243	0.271	0.306	0.336	0.368	0.437	0.470	0.593
	NC (Noise Criteria)	-	-	-	-	-	-	-	21	28
60" x 24" Module	Total Pressure	0.169	0.191	0.214	0.242	0.266	0.292	0.347	0.374	0.474
	NC (Noise Criteria)	-	-	-	-	-	-	-	21	28
72" x 24" Module	Total Pressure	0.140	0.159	0.178	0.202	0.222	0.243	0.291	0.314	0.400
	NC (Noise Criteria)	-	-	-	-	-	-	-	21	28

12" Round Inlet	Airflow (CFM)	215	240	265	295	320	345	400	425	515
48" x 24" Module	Total Pressure	0.206	0.233	0.259	0.291	0.318	0.347	0.409	0.438	0.547
	NC (Noise Criteria)	-	-	-	-	-	-	-	-	21
60" x 24" Module	Total Pressure	0.161	0.181	0.201	0.227	0.248	0.271	0.319	0.343	0.428
	NC (Noise Criteria)	-	-	-	-	-	-	-	-	21
72" x 24" Module	Total Pressure	0.132	0.149	0.166	0.187	0.204	0.222	0.263	0.282	0.353
	NC (Noise Criteria)	-	-	-	-	-	-	-	-	21

PERFORMANCE NOTES

- Performance data includes initial resistance of optional HEPA-R Filter with 2" thick filter media
- Data obtained in accordance with ASHRAE Standard 70-2006
- NC Values are based on a room absorption of 10 dB
- NC levels less than 15 dB are shown as "-"
- All pressures are in inches of water

TLFR-AA / TLFR-SS WITH 23% PERFORATED FACE - 2" FILTER

6" Round Inlet	Airflow (CFM)	100	120	140	160	180	220	240	260	300
48" x 12" Module	Total Pressure	0.301	0.368	0.438	0.510	0.585	0.742	0.824	0.909	1.086
	NC (Noise Criteria)	-	-	-	-	23	30	33	36	41
24" x 24" Module	Total Pressure	0.238	0.292	0.350	0.409	0.472	0.603	0.672	0.744	0.895
	NC (Noise Criteria)	-	-	-	-	23	30	33	36	41
24" x 36" Module	Total Pressure	0.152	0.189	0.229	0.271	0.315	0.409	0.460	0.513	0.626
	NC (Noise Criteria)	-	-	-	-	23	30	33	36	41
24" x 48" Module	Total Pressure	0.116	0.146	0.178	0.212	0.248	0.328	0.371	0.416	0.513
	NC (Noise Criteria)	-	-	-	-	23	30	33	36	41

8" Round Inlet	Airflow (CFM)	100	120	140	160	180	220	240	260	300
60" x 12" Module	Total Pressure	0.221	0.267	0.315	0.363	0.413	0.513	0.565	0.618	0.726
	NC (Noise Criteria)	-	-	-	-	-	-	-	-	21
72" x 12" Module	Total Pressure	0.182	0.220	0.260	0.299	0.341	0.425	0.469	0.513	0.605
	NC (Noise Criteria)	-	-	-	-	-	-	-	-	21
48" x 24" Module	Total Pressure	0.098	0.119	0.142	0.165	0.188	0.239	0.265	0.291	0.347
	NC (Noise Criteria)	-	-	-	-	-	-	-	-	21
24" x 60" Module	Total Pressure	0.078	0.096	0.113	0.132	0.152	0.193	0.215	0.238	0.286
	NC (Noise Criteria)	-	-	-	-	-	-	-	-	21
24" x 72" Module	Total Pressure	0.065	0.080	0.096	0.112	0.129	0.166	0.185	0.204	0.246
	NC (Noise Criteria)	-	-	-	-	-	-	-	-	21

10" Round Inlet	Airflow (CFM)	215	240	265	295	320	345	400	425	515
48" x 24" Module	Total Pressure	0.209	0.237	0.264	0.297	0.325	0.355	0.420	0.451	0.566
	NC (Noise Criteria)	-	-	-	-	-	-	-	21	28
60" x 24" Module	Total Pressure	0.166	0.187	0.209	0.236	0.259	0.284	0.336	0.362	0.457
	NC (Noise Criteria)	-	-	-	-	-	-	-	21	28
72" x 24" Module	Total Pressure	0.138	0.156	0.175	0.198	0.218	0.238	0.284	0.305	0.388
	NC (Noise Criteria)	-	-	-	-	-	-	-	21	28

12" Round Inlet	Airflow (CFM)	215	240	265	295	320	345	400	425	515
48" x 24" Module	Total Pressure	0.201	0.227	0.252	0.282	0.307	0.334	0.392	0.419	0.519
	NC (Noise Criteria)	-	-	-	-	-	-	-	-	21
60" x 24" Module	Total Pressure	0.158	0.177	0.197	0.221	0.241	0.263	0.309	0.331	0.411
	NC (Noise Criteria)	-	-	-	-	-	-	-	-	21
72" x 24" Module	Total Pressure	0.130	0.146	0.163	0.183	0.200	0.217	0.256	0.274	0.341
	NC (Noise Criteria)	-	-	-	-	-	-	-	-	21

PERFORMANCE NOTES

- Performance data includes initial resistance of optional HEPA-R Filter with 2" thick filter media
- Data obtained in accordance with ASHRAE Standard 70-2006
- NC Values are based on a room absorption of 10 dB
- NC levels less than 15 dB are shown as "-"
- All pressures are in inches of water

TLFR-AA / TLFR-SS WITH 33% PERFORATED FACE - 2" FILTER

6" Round Inlet	Airflow (CFM)	100	120	140	160	180	220	240	260	300
48" x 12" Module	Total Pressure	0.299	0.366	0.436	0.507	0.581	0.736	0.817	0.900	1.074
	NC (Noise Criteria)	-	-	-	-	23	30	33	36	41
24" x 24" Module	Total Pressure	0.237	0.291	0.348	0.406	0.468	0.598	0.665	0.736	0.885
	NC (Noise Criteria)	-	-	-	-	23	30	33	36	41
24" x 36" Module	Total Pressure	0.152	0.189	0.228	0.270	0.314	0.407	0.457	0.510	0.622
	NC (Noise Criteria)	-	-	-	-	23	30	33	36	41
24" x 48" Module	Total Pressure	0.116	0.145	0.177	0.212	0.247	0.327	0.370	0.414	0.511
	NC (Noise Criteria)	-	-	-	-	23	30	33	36	41

8" Round Inlet	Airflow (CFM)	100	120	140	160	180	220	240	260	300
60" x 12" Module	Total Pressure	0.220	0.266	0.314	0.361	0.410	0.509	0.560	0.612	0.719
	NC (Noise Criteria)	-	-	-	-	-	-	-	-	21
72" x 12" Module	Total Pressure	0.181	0.220	0.258	0.298	0.340	0.423	0.466	0.510	0.600
	NC (Noise Criteria)	-	-	-	-	-	-	-	-	21
48" x 24" Module	Total Pressure	0.098	0.119	0.141	0.165	0.188	0.238	0.264	0.289	0.345
	NC (Noise Criteria)	-	-	-	-	-	-	-	-	21
24" x 60" Module	Total Pressure	0.078	0.095	0.113	0.132	0.152	0.193	0.215	0.237	0.284
	NC (Noise Criteria)	-	-	-	-	-	-	-	-	21
24" x 72" Module	Total Pressure	0.064	0.080	0.096	0.112	0.129	0.165	0.184	0.203	0.245
	NC (Noise Criteria)	-	-	-	-	-	-	-	-	21

10" Round Inlet	Airflow (CFM)	215	240	265	295	320	345	400	425	515
48" x 24" Module	Total Pressure	0.208	0.235	0.262	0.295	0.323	0.352	0.416	0.446	0.559
	NC (Noise Criteria)	-	-	-	-	-	-	-	21	28
60" x 24" Module	Total Pressure	0.165	0.186	0.208	0.235	0.258	0.282	0.334	0.359	0.453
	NC (Noise Criteria)	-	-	-	-	-	-	-	21	28
72" x 24" Module	Total Pressure	0.138	0.156	0.174	0.197	0.217	0.237	0.282	0.304	0.385
	NC (Noise Criteria)	-	-	-	-	-	-	-	21	28

12" Round Inlet	Airflow (CFM)	215	240	265	295	320	345	400	425	515
48" x 24" Module	Total Pressure	0.200	0.225	0.250	0.280	0.305	0.331	0.388	0.415	0.513
	NC (Noise Criteria)	-	-	-	-	-	-	-	-	21
60" x 24" Module	Total Pressure	0.157	0.176	0.196	0.220	0.240	0.261	0.306	0.328	0.406
	NC (Noise Criteria)	-	-	-	-	-	-	-	-	21
72" x 24" Module	Total Pressure	0.129	0.146	0.162	0.182	0.199	0.216	0.254	0.272	0.339
	NC (Noise Criteria)	-	-	-	-	-	-	-	-	21

PERFORMANCE NOTES

- Performance data includes initial resistance of optional HEPA-R Filter with 2" thick filter media
- Data obtained in accordance with ASHRAE Standard 70-2006
- NC Values are based on a room absorption of 10 dB
- NC levels less than 15 dB are shown as "-"
- All pressures are in inches of water

TLFR-AA / TLFR-SS WITH 13% PERFORATED FACE

6" Round Inlet	Airflow (CFM)	100	120	140	160	180	220	240	260	300
48" x 12" Module	Total Pressure	0.036	0.052	0.070	0.092	0.116	0.173	0.206	0.242	0.322
	NC (Noise Criteria)	-	-	-	-	23	30	33	36	41
24" x 24" Module	Total Pressure	0.035	0.050	0.068	0.089	0.113	0.168	0.200	0.235	0.313
	NC (Noise Criteria)	-	-	-	-	23	30	33	36	41
24" x 36" Module	Total Pressure	0.030	0.043	0.059	0.077	0.097	0.145	0.173	0.203	0.270
	NC (Noise Criteria)	-	-	-	-	23	30	33	36	41
24" x 48" Module	Total Pressure	0.028	0.041	0.056	0.073	0.092	0.138	0.164	0.193	0.256
	NC (Noise Criteria)	-	-	-	-	23	30	33	36	41

8" Round Inlet	Airflow (CFM)	100	120	140	160	180	220	240	260	300
60" x 12" Module	Total Pressure	0.014	0.020	0.027	0.036	0.045	0.068	0.081	0.095	0.126
	NC (Noise Criteria)	-	-	-	-	-	-	-	-	21
72" x 12" Module	Total Pressure	0.012	0.018	0.024	0.031	0.040	0.059	0.070	0.082	0.110
	NC (Noise Criteria)	-	-	-	-	-	-	-	-	21
48" x 24" Module	Total Pressure	0.010	0.015	0.020	0.026	0.033	0.049	0.058	0.068	0.091
	NC (Noise Criteria)	-	-	-	-	-	-	-	-	21
24" x 60" Module	Total Pressure	0.009	0.014	0.018	0.024	0.030	0.046	0.054	0.064	0.085
	NC (Noise Criteria)	-	-	-	-	-	-	-	-	21
24" x 72" Module	Total Pressure	0.009	0.013	0.018	0.023	0.029	0.044	0.052	0.061	0.081
	NC (Noise Criteria)	-	-	-	-	-	-	-	-	21

10" Round Inlet	Airflow (CFM)	215	240	265	295	320	345	400	425	515
48" x 24" Module	Total Pressure	0.024	0.030	0.036	0.045	0.053	0.062	0.083	0.094	0.137
	NC (Noise Criteria)	-	-	-	-	-	-	-	21	28
60" x 24" Module	Total Pressure	0.021	0.026	0.032	0.039	0.046	0.054	0.072	0.081	0.119
	NC (Noise Criteria)	-	-	-	-	-	-	-	21	28
72" x 24" Module	Total Pressure	0.019	0.024	0.029	0.036	0.042	0.049	0.066	0.075	0.110
	NC (Noise Criteria)	-	-	-	-	-	-	-	21	28

12" Round Inlet	Airflow (CFM)	215	240	265	295	320	345	400	425	515
48" x 24" Module	Total Pressure	0.016	0.020	0.024	0.030	0.035	0.041	0.055	0.062	0.091
	NC (Noise Criteria)	-	-	-	-	-	-	-	-	21
60" x 24" Module	Total Pressure	0.013	0.016	0.019	0.024	0.028	0.033	0.044	0.050	0.073
	NC (Noise Criteria)	-	-	-	-	-	-	-	-	21
72" x 24" Module	Total Pressure	0.011	0.014	0.017	0.021	0.024	0.028	0.038	0.043	0.063
	NC (Noise Criteria)	-	-	-	-	-	-	-	-	21

PERFORMANCE NOTES

- Performance data includes pressure loss associated with optional snap-in equalization baffle
- Performance data does not account for optional filter pressure loss
- Data obtained in accordance with ASHRAE Standard 70-2006
- NC Values are based on a room absorption of 10 dB
- NC levels less than 15 dB are shown as "-"
- All pressures are in inches of water

TLFR-AA / TLFR-SS WITH 23% PERFORATED FACE

6" Round Inlet	Airflow (CFM)	100	120	140	160	180	220	240	260	300
48" x 12" Module	Total Pressure	0.031	0.044	0.060	0.078	0.099	0.148	0.176	0.207	0.276
	NC (Noise Criteria)	-	-	-	-	23	30	33	36	41
24" x 24" Module	Total Pressure	0.030	0.043	0.059	0.077	0.098	0.146	0.174	0.204	0.272
	NC (Noise Criteria)	-	-	-	-	23	30	33	36	41
24" x 36" Module	Total Pressure	0.028	0.040	0.055	0.072	0.091	0.136	0.162	0.190	0.253
	NC (Noise Criteria)	-	-	-	-	23	30	33	36	41
24" x 48" Module	Total Pressure	0.027	0.040	0.054	0.070	0.089	0.133	0.158	0.186	0.247
	NC (Noise Criteria)	-	-	-	-	23	30	33	36	41

8" Round Inlet	Airflow (CFM)	100	120	140	160	180	220	240	260	300
60" x 12" Module	Total Pressure	0.011	0.015	0.021	0.027	0.035	0.052	0.062	0.073	0.097
	NC (Noise Criteria)	-	-	-	-	-	-	-	-	21
72" x 12" Module	Total Pressure	0.010	0.014	0.020	0.025	0.032	0.048	0.057	0.067	0.090
	NC (Noise Criteria)	-	-	-	-	-	-	-	-	21
48" x 24" Module	Total Pressure	0.009	0.013	0.018	0.023	0.029	0.044	0.052	0.061	0.081
	NC (Noise Criteria)	-	-	-	-	-	-	-	-	21
24" x 60" Module	Total Pressure	0.009	0.013	0.017	0.022	0.028	0.042	0.050	0.059	0.079
	NC (Noise Criteria)	-	-	-	-	-	-	-	-	21
24" x 72" Module	Total Pressure	0.009	0.012	0.017	0.022	0.028	0.042	0.050	0.058	0.077
	NC (Noise Criteria)	-	-	-	-	-	-	-	-	21

10" Round Inlet	Airflow (CFM)	215	240	265	295	320	345	400	425	515
48" x 24" Module	Total Pressure	0.019	0.024	0.029	0.036	0.042	0.049	0.066	0.075	0.110
	NC (Noise Criteria)	-	-	-	-	-	-	-	21	28
60" x 24" Module	Total Pressure	0.018	0.022	0.027	0.033	0.039	0.046	0.061	0.069	0.102
	NC (Noise Criteria)	-	-	-	-	-	-	-	21	28
72" x 24" Module	Total Pressure	0.017	0.021	0.026	0.032	0.038	0.044	0.059	0.066	0.098
	NC (Noise Criteria)	-	-	-	-	-	-	-	21	28

12" Round Inlet	Airflow (CFM)	215	240	265	295	320	345	400	425	515
48" x 24" Module	Total Pressure	0.011	0.014	0.017	0.021	0.024	0.028	0.038	0.043	0.063
	NC (Noise Criteria)	-	-	-	-	-	-	-	-	21
60" x 24" Module	Total Pressure	0.010	0.012	0.015	0.018	0.021	0.025	0.034	0.038	0.056
	NC (Noise Criteria)	-	-	-	-	-	-	-	-	21
72" x 24" Module	Total Pressure	0.009	0.011	0.014	0.017	0.020	0.023	0.031	0.035	0.051
	NC (Noise Criteria)	-	-	-	-	-	-	-	-	21

PERFORMANCE NOTES

- Performance data includes pressure loss associated with optional snap-in equalization baffle
- Performance data does not account for optional filter pressure loss
- Data obtained in accordance with ASHRAE Standard 70-2006
- NC Values are based on a room absorption of 10 dB
- NC levels less than 15 dB are shown as "-"
- All pressures are in inches of water

TLFR-AA / TLFR-SS WITH 33% PERFORATED FACE

6" Round Inlet	Airflow (CFM)	100	120	140	160	180	220	240	260	300
48" x 12" Module	Total Pressure	0.029	0.042	0.058	0.075	0.095	0.142	0.169	0.198	0.264
	NC (Noise Criteria)	-	-	-	-	23	30	33	36	41
24" x 24" Module	Total Pressure	0.029	0.042	0.057	0.074	0.094	0.141	0.167	0.196	0.262
	NC (Noise Criteria)	-	-	-	-	23	30	33	36	41
24" x 36" Module	Total Pressure	0.028	0.040	0.054	0.071	0.090	0.134	0.159	0.187	0.249
	NC (Noise Criteria)	-	-	-	-	23	30	33	36	41
24" x 48" Module	Total Pressure	0.027	0.039	0.053	0.070	0.088	0.132	0.157	0.184	0.245
	NC (Noise Criteria)	-	-	-	-	23	30	33	36	41

8" Round Inlet	Airflow (CFM)	100	120	140	160	180	220	240	260	300
60" x 12" Module	Total Pressure	0.010	0.014	0.020	0.025	0.032	0.048	0.057	0.067	0.090
	NC (Noise Criteria)	-	-	-	-	-	-	-	-	21
72" x 12" Module	Total Pressure	0.009	0.014	0.018	0.024	0.031	0.046	0.054	0.064	0.085
	NC (Noise Criteria)	-	-	-	-	-	-	-	-	21
48" x 24" Module	Total Pressure	0.009	0.013	0.017	0.023	0.029	0.043	0.051	0.059	0.079
	NC (Noise Criteria)	-	-	-	-	-	-	-	-	21
24" x 60" Module	Total Pressure	0.009	0.012	0.017	0.022	0.028	0.042	0.050	0.058	0.077
	NC (Noise Criteria)	-	-	-	-	-	-	-	-	21
24" x 72" Module	Total Pressure	0.008	0.012	0.017	0.022	0.028	0.041	0.049	0.057	0.076
	NC (Noise Criteria)	-	-	-	-	-	-	-	-	21

10" Round Inlet	Airflow (CFM)	215	240	265	295	320	345	400	425	515
48" x 24" Module	Total Pressure	0.018	0.022	0.027	0.034	0.040	0.046	0.062	0.070	0.103
	NC (Noise Criteria)	-	-	-	-	-	-	-	21	28
60" x 24" Module	Total Pressure	0.017	0.021	0.026	0.032	0.038	0.044	0.059	0.066	0.098
	NC (Noise Criteria)	-	-	-	-	-	-	-	21	28
72" x 24" Module	Total Pressure	0.017	0.021	0.025	0.031	0.037	0.043	0.057	0.065	0.095
	NC (Noise Criteria)	-	-	-	-	-	-	-	21	28

12" Round Inlet	Airflow (CFM)	215	240	265	295	320	345	400	425	515
48" x 24" Module	Total Pressure	0.010	0.012	0.015	0.019	0.022	0.025	0.034	0.039	0.057
	NC (Noise Criteria)	-	-	-	-	-	-	-	-	21
60" x 24" Module	Total Pressure	0.009	0.011	0.014	0.017	0.020	0.023	0.031	0.035	0.051
	NC (Noise Criteria)	-	-	-	-	-	-	-	-	21
72" x 24" Module	Total Pressure	0.008	0.011	0.013	0.016	0.019	0.022	0.029	0.033	0.049
	NC (Noise Criteria)	-	-	-	-	-	-	-	-	21

PERFORMANCE NOTES

- Performance data includes pressure loss associated with optional snap-in equalization baffle
- Performance data does not account for optional filter pressure loss
- Data obtained in accordance with ASHRAE Standard 70-2006
- NC Values are based on a room absorption of 10 dB
- NC levels less than 15 dB are shown as "-"
- All pressures are in inches of water

## TLFR-LED

- Ideal for installation in hospital operating rooms
- Integral LED luminaire with tunable color temperature @ 90 CRI
- Snap-in, tool-less HEPA filter installation and removal
- Factory pressure tested
- Roomside accessible control enclosure
- Roomside accessible PAO challenge port option
- Perforated face quickly removes by loosening quarter-turn fasteners
- Three free area options
- Accommodates filters with 2", 3", & 4" media packs
- Compatible with 1" or 1½" T-bar ceiling grids

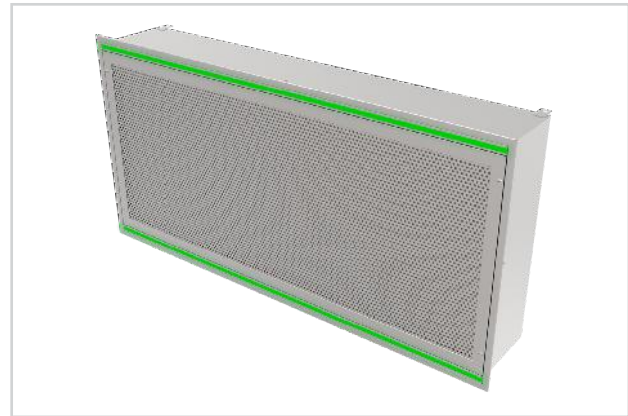

TLFR-LED



hospitals

surgical

cleanrooms

research labs



See website for Specifications

### MODELS:

TLFR-AA-LED / Aluminum  
TLFR-LED / 304 Stainless Steel

### FINISHES:

Standard Finish - #26 White  
Optional Finish - #04 Mill

### OVERVIEW

#### Vertical Laminar Flow Technology

The next generation Titus unidirectional flow diffuser for critical environments has been designed to comply with industry standard, ASHRAE 170, offering important safeguards for surgical patients. Used in operating rooms as the primary diffusers, the vertical piston of air created by the TLFR-LED is used to discharge clean air over the patient during operations. The integration of high-output, high-efficiency LED lighting eliminates the need for specialized luminaires around the perimeter of the diffuser array. The integrated LED lighting improves lighting quality over the operating table or workspace with more direct lighting and less shadows. Eliminating the need for the perimeter lighting reduces installed components, enabling more flexibility for placement of diffusers and ceiling mounted equipment. Including snap-in, auto-centering filter retainers, the new TLFR-LED reduces the amount of time and effort during installation and removal of filters. This decreases the time a lab or operating suite is out of commission, allowing facilities to maximize profitability and patient care.

Unidirectional flow minimizes air induction, reducing the opportunity for contaminated air to be re-entrained and pollute a clean airstream.

The TLFR-LED Series of laminar flow diffusers generates a low velocity, evenly distributed, downward moving "piston" of conditioned air.

Installed over the operating table in a hospital operating room, TLFR-LED diffusers help protect the patient from contaminated room secondary air. The only appreciable amount of room air entrainment occurs at the boundaries of the moving air mass, outside the confines of the operating table. As a result, the patient is effectively isolated from residual room air.

TLFR-LED is especially effective in cooling areas with heavy, localized, internal loads, as in computer rooms. The column of air delivered by the TLFR-LED cools the load source directly without generating high velocities in the occupied space.



TLFR-LED UNIT DIMENSIONS

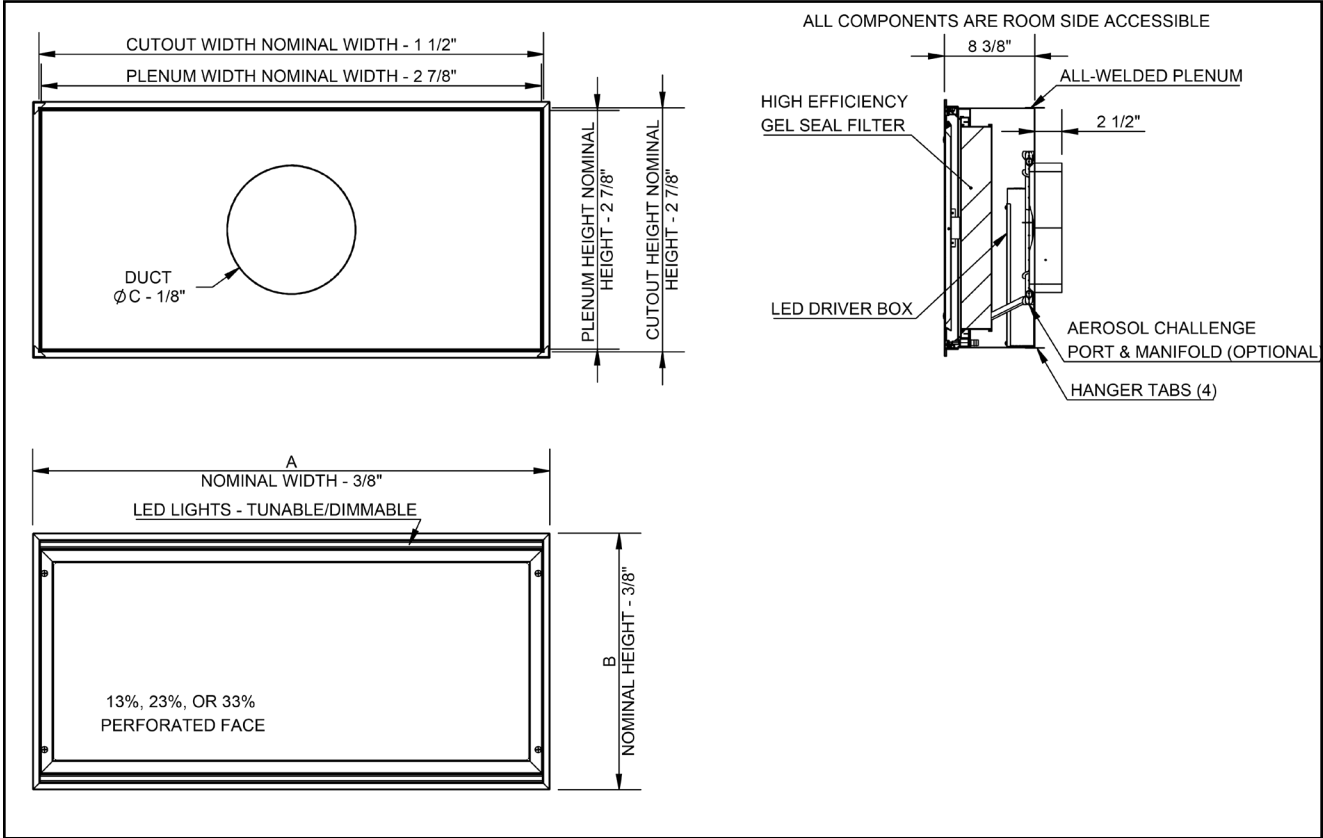

Module Size	A	B
24 x 12	23 <sup>5</sup> / <sub>8</sub> "	11 <sup>5</sup> / <sub>8</sub> "
24 x 24	23 <sup>5</sup> / <sub>8</sub> "	23 <sup>5</sup> / <sub>8</sub> "
36 x 12	35 <sup>5</sup> / <sub>8</sub> "	11 <sup>5</sup> / <sub>8</sub> "
48 x 12	47 <sup>5</sup> / <sub>8</sub> "	11 <sup>5</sup> / <sub>8</sub> "
48 x 24	47 <sup>5</sup> / <sub>8</sub> "	23 <sup>5</sup> / <sub>8</sub> "
60 x 12	59 <sup>5</sup> / <sub>8</sub> "	11 <sup>5</sup> / <sub>8</sub> "
60 x 24	59 <sup>5</sup> / <sub>8</sub> "	23 <sup>5</sup> / <sub>8</sub> "

Nominal Inlet Size	C
6	5 <sup>7</sup> / <sub>8</sub> "
8	7 <sup>7</sup> / <sub>8</sub> "
10	9 <sup>7</sup> / <sub>8</sub> "
12	11 <sup>7</sup> / <sub>8</sub> "

R

OPTIONAL ACCESSORIES

Cable Operated Damper Detail

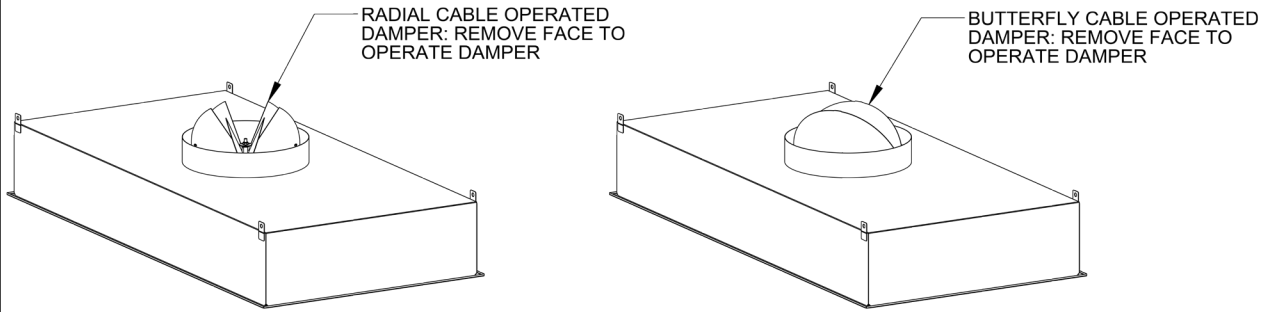

Control Enclosure & Accessory Detail

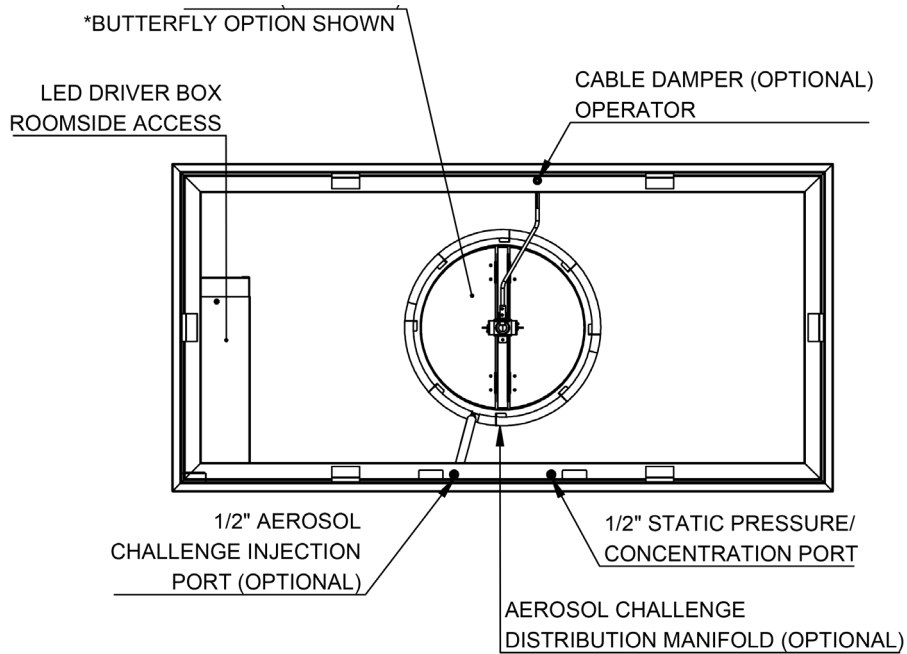

**FACE FRAME AND FILTER REMOVED FOR CLARITY**

UNIT WIRING

LED LIGHTING WIRING DIAGRAM

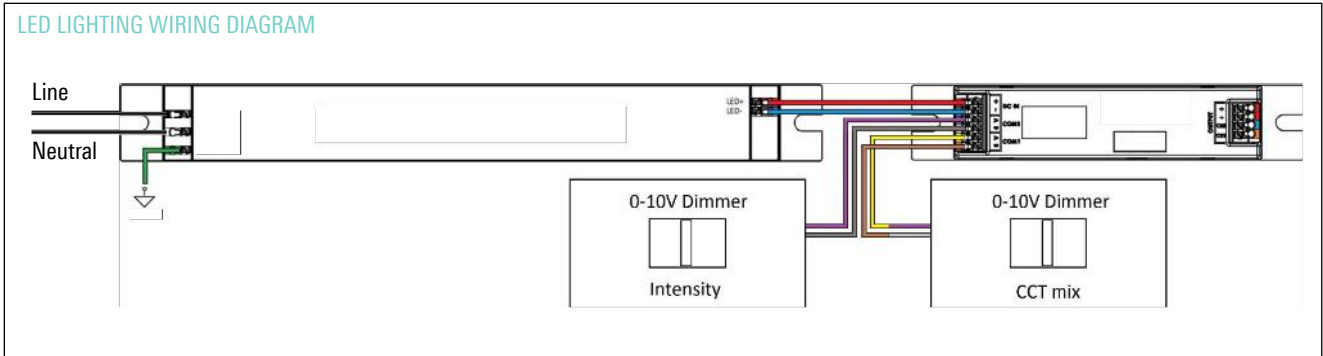

Note: Dimmers to be provided by others. Tunable White and Tunable Green to White configurations require dimmers for both intensity and color temperature.

Integrated LED Detail

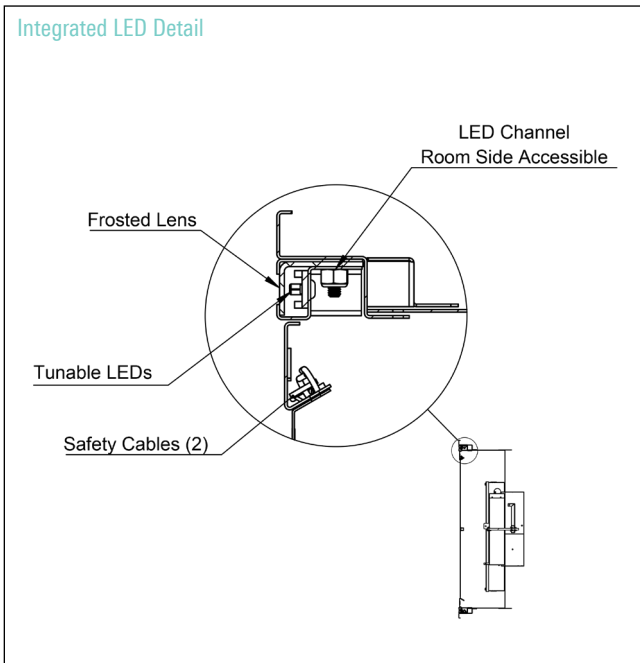

Knife Edge/Gel Seal Detail

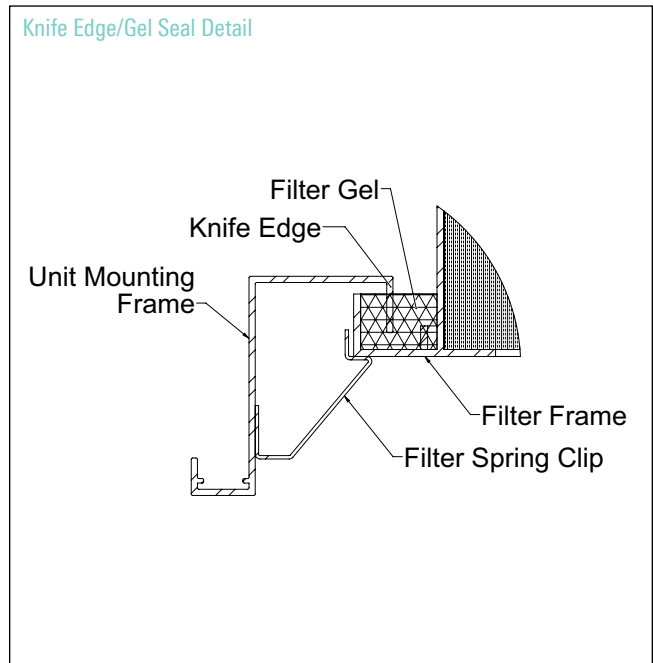

TLFR-AA-LED / TLFR-SS-LED WITH 13% PERFORATED FACE - 2" FILTER

6" Round Inlet	Airflow (CFM)	100	120	140	160	180	220	240	260	300
48" x 12" Module	Total Pressure	0.306	0.376	0.448	0.524	0.602	0.767	0.854	0.944	1.132
	NC (Noise Criteria)	-	-	-	-	23	30	33	36	41
24" x 24" Module	Total Pressure	0.243	0.299	0.359	0.421	0.487	0.625	0.698	0.775	0.936
	NC (Noise Criteria)	-	-	-	-	23	30	33	36	41
24" x 48" Module	Total Pressure	0.117	0.147	0.180	0.215	0.251	0.333	0.377	0.423	0.522
	NC (Noise Criteria)	-	-	-	-	23	30	33	36	41

8" Round Inlet	Airflow (CFM)	100	120	140	160	180	220	240	260	300
60" x 12" Module	Total Pressure	0.224	0.272	0.321	0.372	0.423	0.529	0.584	0.640	0.755
	NC (Noise Criteria)	-	-	-	-	-	-	-	-	21
48" x 24" Module	Total Pressure	0.099	0.121	0.144	0.168	0.192	0.244	0.271	0.298	0.357
	NC (Noise Criteria)	-	-	-	-	-	-	-	-	21
24" x 60" Module	Total Pressure	0.078	0.097	0.114	0.134	0.154	0.197	0.219	0.243	0.292
	NC (Noise Criteria)	-	-	-	-	-	-	-	-	21

10" Round Inlet	Airflow (CFM)	215	240	265	295	320	345	400	425	515
48" x 24" Module	Total Pressure	0.214	0.243	0.271	0.306	0.336	0.368	0.437	0.470	0.593
	NC (Noise Criteria)	-	-	-	-	-	-	-	21	28
60" x 24" Module	Total Pressure	0.169	0.191	0.214	0.242	0.266	0.292	0.347	0.374	0.474
	NC (Noise Criteria)	-	-	-	-	-	-	-	21	28

12" Round Inlet	Airflow (CFM)	215	240	265	295	320	345	400	425	515
48" x 24" Module	Total Pressure	0.206	0.233	0.259	0.291	0.318	0.347	0.409	0.438	0.547
	NC (Noise Criteria)	-	-	-	-	-	-	-	-	21
60" x 24" Module	Total Pressure	0.161	0.181	0.201	0.227	0.248	0.271	0.319	0.343	0.428
	NC (Noise Criteria)	-	-	-	-	-	-	-	-	21

PERFORMANCE NOTES

- Performance data includes initial resistance of optional HEPA-R Filter with 2" thick filter media
- Data obtained in accordance with ASHRAE Standard 70-2006
- NC Values are based on a room absorption of 10 dB
- NC levels less than 15 dB are shown as "-"
- All pressures are in inches of water

TLFR-AA-LED / TLFR-SS-LED WITH 23% PERFORATED FACE - 2" FILTER

6" Round Inlet	Airflow (CFM)	100	120	140	160	180	220	240	260	300
48" x 12" Module	Total Pressure	0.301	0.368	0.438	0.510	0.585	0.742	0.824	0.909	1.086
	NC (Noise Criteria)	-	-	-	-	23	30	33	36	41
24" x 24" Module	Total Pressure	0.238	0.292	0.350	0.409	0.472	0.603	0.672	0.744	0.895
	NC (Noise Criteria)	-	-	-	-	23	30	33	36	41
24" x 48" Module	Total Pressure	0.116	0.146	0.178	0.212	0.248	0.328	0.371	0.416	0.513
	NC (Noise Criteria)	-	-	-	-	23	30	33	36	41

8" Round Inlet	Airflow (CFM)	100	120	140	160	180	220	240	260	300
60" x 12" Module	Total Pressure	0.221	0.267	0.315	0.363	0.413	0.513	0.565	0.618	0.726
	NC (Noise Criteria)	-	-	-	-	-	-	-	-	21
48" x 24" Module	Total Pressure	0.098	0.119	0.142	0.165	0.188	0.239	0.265	0.291	0.347
	NC (Noise Criteria)	-	-	-	-	-	-	-	-	21
24" x 60" Module	Total Pressure	0.078	0.096	0.113	0.132	0.152	0.193	0.215	0.238	0.286
	NC (Noise Criteria)	-	-	-	-	-	-	-	-	21

10" Round Inlet	Airflow (CFM)	215	240	265	295	320	345	400	425	515
48" x 24" Module	Total Pressure	0.209	0.237	0.264	0.297	0.325	0.355	0.420	0.451	0.566
	NC (Noise Criteria)	-	-	-	-	-	-	-	21	28
60" x 24" Module	Total Pressure	0.166	0.187	0.209	0.236	0.259	0.284	0.336	0.362	0.457
	NC (Noise Criteria)	-	-	-	-	-	-	-	21	28

12" Round Inlet	Airflow (CFM)	215	240	265	295	320	345	400	425	515
48" x 24" Module	Total Pressure	0.201	0.227	0.252	0.282	0.307	0.334	0.392	0.419	0.519
	NC (Noise Criteria)	-	-	-	-	-	-	-	-	21
60" x 24" Module	Total Pressure	0.158	0.177	0.197	0.221	0.241	0.263	0.309	0.331	0.411
	NC (Noise Criteria)	-	-	-	-	-	-	-	-	21

PERFORMANCE NOTES

- Performance data includes initial resistance of optional HEPA-R Filter with 2" thick filter media
- Data obtained in accordance with ASHRAE Standard 70-2006
- NC Values are based on a room absorption of 10 dB
- NC levels less than 15 dB are shown as "-"
- All pressures are in inches of water

TLFR-AA-LED / TLFR-SS-LED WITH 33% PERFORATED FACE - 2" FILTER

6" Round Inlet	Airflow (CFM)	100	120	140	160	180	220	240	260	300
48" x 12" Module	Total Pressure	0.299	0.366	0.436	0.507	0.581	0.736	0.817	0.900	1.074
	NC (Noise Criteria)	-	-	-	-	23	30	33	36	41
24" x 24" Module	Total Pressure	0.237	0.291	0.348	0.406	0.468	0.598	0.665	0.736	0.885
	NC (Noise Criteria)	-	-	-	-	23	30	33	36	41
24" x 48" Module	Total Pressure	0.116	0.145	0.177	0.212	0.247	0.327	0.370	0.414	0.511
	NC (Noise Criteria)	-	-	-	-	23	30	33	36	41

8" Round Inlet	Airflow (CFM)	100	120	140	160	180	220	240	260	300
60" x 12" Module	Total Pressure	0.220	0.266	0.314	0.361	0.410	0.509	0.560	0.612	0.719
	NC (Noise Criteria)	-	-	-	-	-	-	-	-	21
48" x 24" Module	Total Pressure	0.098	0.119	0.141	0.165	0.188	0.238	0.264	0.289	0.345
	NC (Noise Criteria)	-	-	-	-	-	-	-	-	21
24" x 60" Module	Total Pressure	0.078	0.095	0.113	0.132	0.152	0.193	0.215	0.237	0.284
	NC (Noise Criteria)	-	-	-	-	-	-	-	-	21

10" Round Inlet	Airflow (CFM)	215	240	265	295	320	345	400	425	515
48" x 24" Module	Total Pressure	0.208	0.235	0.262	0.295	0.323	0.352	0.416	0.446	0.559
	NC (Noise Criteria)	-	-	-	-	-	-	-	21	28
60" x 24" Module	Total Pressure	0.165	0.186	0.208	0.235	0.258	0.282	0.334	0.359	0.453
	NC (Noise Criteria)	-	-	-	-	-	-	-	21	28

12" Round Inlet	Airflow (CFM)	215	240	265	295	320	345	400	425	515
48" x 24" Module	Total Pressure	0.200	0.225	0.250	0.280	0.305	0.331	0.388	0.415	0.513
	NC (Noise Criteria)	-	-	-	-	-	-	-	-	21
60" x 24" Module	Total Pressure	0.157	0.176	0.196	0.220	0.240	0.261	0.306	0.328	0.406
	NC (Noise Criteria)	-	-	-	-	-	-	-	-	21

PERFORMANCE NOTES

- Performance data includes initial resistance of optional HEPA-R Filter with 2" thick filter media
- Data obtained in accordance with ASHRAE Standard 70-2006
- NC Values are based on a room absorption of 10 dB
- NC levels less than 15 dB are shown as "-"
- All pressures are in inches of water

TLFR-AA-LED / TLFR-SS-LED WITH 13% PERFORATED FACE

6" Round Inlet	Airflow (CFM)	100	120	140	160	180	220	240	260	300
48" x 12" Module	Total Pressure	0.036	0.052	0.070	0.092	0.116	0.173	0.206	0.242	0.322
	NC (Noise Criteria)	-	-	-	-	23	30	33	36	41
24" x 24" Module	Total Pressure	0.035	0.050	0.068	0.089	0.113	0.168	0.200	0.235	0.313
	NC (Noise Criteria)	-	-	-	-	23	30	33	36	41
24" x 48" Module	Total Pressure	0.028	0.041	0.056	0.073	0.092	0.138	0.164	0.193	0.256
	NC (Noise Criteria)	-	-	-	-	23	30	33	36	41

8" Round Inlet	Airflow (CFM)	100	120	140	160	180	220	240	260	300
60" x 12" Module	Total Pressure	0.014	0.020	0.027	0.036	0.045	0.068	0.081	0.095	0.126
	NC (Noise Criteria)	-	-	-	-	-	-	-	-	21
48" x 24" Module	Total Pressure	0.010	0.015	0.020	0.026	0.033	0.049	0.058	0.068	0.091
	NC (Noise Criteria)	-	-	-	-	-	-	-	-	21
24" x 60" Module	Total Pressure	0.009	0.014	0.018	0.024	0.030	0.046	0.054	0.064	0.085
	NC (Noise Criteria)	-	-	-	-	-	-	-	-	21

10" Round Inlet	Airflow (CFM)	215	240	265	295	320	345	400	425	515
48" x 24" Module	Total Pressure	0.024	0.030	0.036	0.045	0.053	0.062	0.083	0.094	0.137
	NC (Noise Criteria)	-	-	-	-	-	-	-	21	28
60" x 24" Module	Total Pressure	0.021	0.026	0.032	0.039	0.046	0.054	0.072	0.081	0.119
	NC (Noise Criteria)	-	-	-	-	-	-	-	21	28

12" Round Inlet	Airflow (CFM)	215	240	265	295	320	345	400	425	515
48" x 24" Module	Total Pressure	0.016	0.020	0.024	0.030	0.035	0.041	0.055	0.062	0.091
	NC (Noise Criteria)	-	-	-	-	-	-	-	-	21
60" x 24" Module	Total Pressure	0.013	0.016	0.019	0.024	0.028	0.033	0.044	0.050	0.073
	NC (Noise Criteria)	-	-	-	-	-	-	-	-	21

PERFORMANCE NOTES

- Performance data includes pressure loss associated with optional snap-in equalization baffle
- Performance data does not account for optional filter pressure loss
- Data obtained in accordance with ASHRAE Standard 70-2006
- NC Values are based on a room absorption of 10 dB
- NC levels less than 15 dB are shown as "-"
- All pressures are in inches of water

TLFR-AA-LED / TLFR-SS-LED WITH 23% PERFORATED FACE

6" Round Inlet	Airflow (CFM)	100	120	140	160	180	220	240	260	300
48" x 12" Module	Total Pressure	0.031	0.044	0.060	0.078	0.099	0.148	0.176	0.207	0.276
	NC (Noise Criteria)	-	-	-	-	23	30	33	36	41
24" x 24" Module	Total Pressure	0.030	0.043	0.059	0.077	0.098	0.146	0.174	0.204	0.272
	NC (Noise Criteria)	-	-	-	-	23	30	33	36	41
24" x 48" Module	Total Pressure	0.027	0.040	0.054	0.070	0.089	0.133	0.158	0.186	0.247
	NC (Noise Criteria)	-	-	-	-	23	30	33	36	41

8" Round Inlet	Airflow (CFM)	100	120	140	160	180	220	240	260	300
60" x 12" Module	Total Pressure	0.011	0.015	0.021	0.027	0.035	0.052	0.062	0.073	0.097
	NC (Noise Criteria)	-	-	-	-	-	-	-	-	21
48" x 24" Module	Total Pressure	0.009	0.013	0.018	0.023	0.029	0.044	0.052	0.061	0.081
	NC (Noise Criteria)	-	-	-	-	-	-	-	-	21
24" x 60" Module	Total Pressure	0.009	0.013	0.017	0.022	0.028	0.042	0.050	0.059	0.079
	NC (Noise Criteria)	-	-	-	-	-	-	-	-	21

10" Round Inlet	Airflow (CFM)	215	240	265	295	320	345	400	425	515
48" x 24" Module	Total Pressure	0.019	0.024	0.029	0.036	0.042	0.049	0.066	0.075	0.110
	NC (Noise Criteria)	-	-	-	-	-	-	-	21	28
60" x 24" Module	Total Pressure	0.018	0.022	0.027	0.033	0.039	0.046	0.061	0.069	0.102
	NC (Noise Criteria)	-	-	-	-	-	-	-	21	28

12" Round Inlet	Airflow (CFM)	215	240	265	295	320	345	400	425	515
48" x 24" Module	Total Pressure	0.011	0.014	0.017	0.021	0.024	0.028	0.038	0.043	0.063
	NC (Noise Criteria)	-	-	-	-	-	-	-	-	21
60" x 24" Module	Total Pressure	0.010	0.012	0.015	0.018	0.021	0.025	0.034	0.038	0.056
	NC (Noise Criteria)	-	-	-	-	-	-	-	-	21

PERFORMANCE NOTES

- Performance data includes pressure loss associated with optional snap-in equalization baffle
- Performance data does not account for optional filter pressure loss
- Data obtained in accordance with ASHRAE Standard 70-2006
- NC Values are based on a room absorption of 10 dB
- NC levels less than 15 dB are shown as "-"
- All pressures are in inches of water



TLFR-AA-LED / TLFR-SS-LED WITH 33% PERFORATED FACE

6" Round Inlet	Airflow (CFM)	100	120	140	160	180	220	240	260	300
48" x 12" Module	Total Pressure	0.029	0.042	0.058	0.075	0.095	0.142	0.169	0.198	0.264
	NC (Noise Criteria)	-	-	-	-	23	30	33	36	41
24" x 24" Module	Total Pressure	0.029	0.042	0.057	0.074	0.094	0.141	0.167	0.196	0.262
	NC (Noise Criteria)	-	-	-	-	23	30	33	36	41
24" x 48" Module	Total Pressure	0.027	0.039	0.053	0.070	0.088	0.132	0.157	0.184	0.245
	NC (Noise Criteria)	-	-	-	-	23	30	33	36	41

8" Round Inlet	Airflow (CFM)	100	120	140	160	180	220	240	260	300
60" x 12" Module	Total Pressure	0.010	0.014	0.020	0.025	0.032	0.048	0.057	0.067	0.090
	NC (Noise Criteria)	-	-	-	-	-	-	-	-	21
48" x 24" Module	Total Pressure	0.009	0.013	0.017	0.023	0.029	0.043	0.051	0.059	0.079
	NC (Noise Criteria)	-	-	-	-	-	-	-	-	21
24" x 60" Module	Total Pressure	0.009	0.012	0.017	0.022	0.028	0.042	0.050	0.058	0.077
	NC (Noise Criteria)	-	-	-	-	-	-	-	-	21

10" Round Inlet	Airflow (CFM)	215	240	265	295	320	345	400	425	515
48" x 24" Module	Total Pressure	0.018	0.022	0.027	0.034	0.040	0.046	0.062	0.070	0.103
	NC (Noise Criteria)	-	-	-	-	-	-	-	21	28
60" x 24" Module	Total Pressure	0.017	0.021	0.026	0.032	0.038	0.044	0.059	0.066	0.098
	NC (Noise Criteria)	-	-	-	-	-	-	-	21	28

12" Round Inlet	Airflow (CFM)	215	240	265	295	320	345	400	425	515
48" x 24" Module	Total Pressure	0.010	0.012	0.015	0.019	0.022	0.025	0.034	0.039	0.057
	NC (Noise Criteria)	-	-	-	-	-	-	-	-	21
60" x 24" Module	Total Pressure	0.009	0.011	0.014	0.017	0.020	0.023	0.031	0.035	0.051
	NC (Noise Criteria)	-	-	-	-	-	-	-	-	21

PERFORMANCE NOTES

- Performance data includes pressure loss associated with optional snap-in equalization baffle
- Performance data does not account for optional filter pressure loss
- Data obtained in accordance with ASHRAE Standard 70-2006
- NC Values are based on a room absorption of 10 dB
- NC levels less than 15 dB are shown as "-"
- All pressures are in inches of water

### LineaTec

- LineaTec provides a curtain of supply air
- Blades have minimum adjustability to allow precise control of the air curtain angle
- Face available in 304 Stainless Steel or aluminum
- Available in single sections up to 96 inches long or multiple sections for continuous runs
- Available with optional 304 Stainless Steel or aluminum plenums
- Available in 1-slot or 2-slot configurations
- Plenums available with square or round corners, quarter-turn fasteners for easy face removal and sanitizing
- Excellent for use as a perimeter air curtain in clean air environments such as operating rooms
- May be used in surface mount or lay-in applications

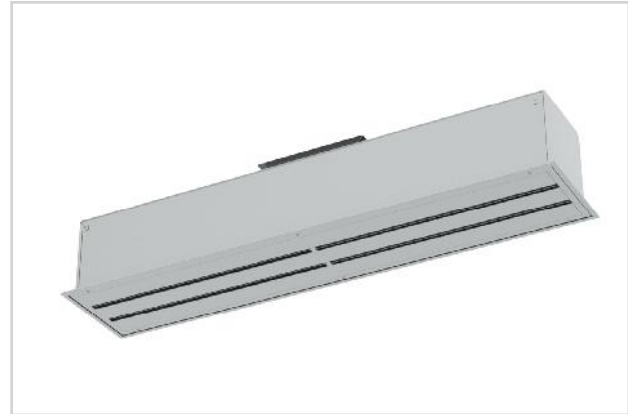

LINEATEC



hospitals



surgical

#### MODELS:

LineaTec-AL / Aluminum  
LineaTec-SS / 304 Stainless Steel

#### FINISHES:

Standard Finish - #26 White Face (aluminum models)  
Optional Finish - #04 Mill (304 stainless steel models and plenums)

#### OVERVIEW

Linear Air Curtain Technology Vertical Air Curtain Diffuser for Perimeter Control of Pollutants

LineaTec is a linear air curtain diffuser used to create an air curtain barrier between a clean zone and the balance of the room. The air curtain typically discharges 25 to 50 cfm per linear foot of slot. Flow rates of up to 100 cfm per linear foot of diffuser can be obtained with a two-slot LineaTec. LineaTec diffusers are typically used to surround TLF diffusers in operating rooms to reduce internal contaminants in the sterile zone of the operating theatre. With limited adjustable slots, the air curtain can be directed at a slight angle to facilitate balancing airflow in the entire operating theatre through directional control.

To meet sanitizing requirements, LineaTec diffusers are available with plenums that have optional corners radiused to  $\frac{3}{4}$ ". This allows easy manual cleaning of the inside of the plenum when the face is removed and reduces crevices where bacteria and other organisms can grow. Select LineaTec diffusers based on 50 fpm terminal velocity at knee height to 24 inches above floor - for most operating room applications.



See website for Specifications

LINEATEC UNIT DIMENSIONS - SINGLE PIECE CONSTRUCTION

LineaTec - Side View

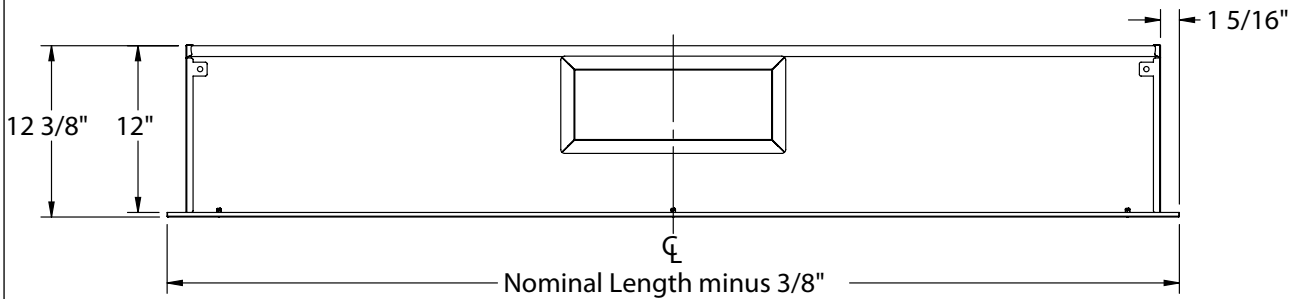

Note: Maximum single piece construction Nominal Length is 100"  
Minimum Nominal Length is 24"  
Inlets centered on section unless specified

LineaTec - End View

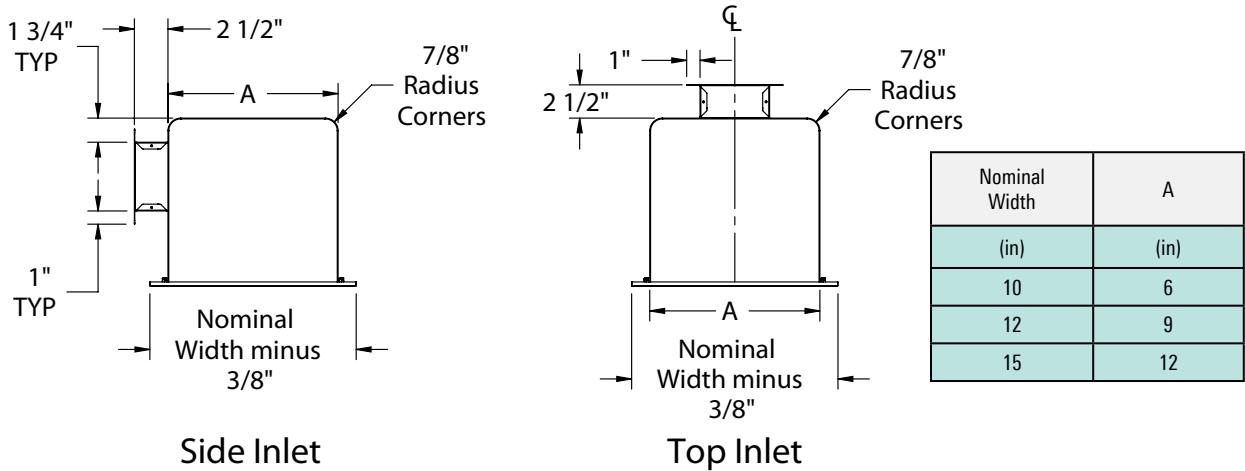

LineaTec - Face View

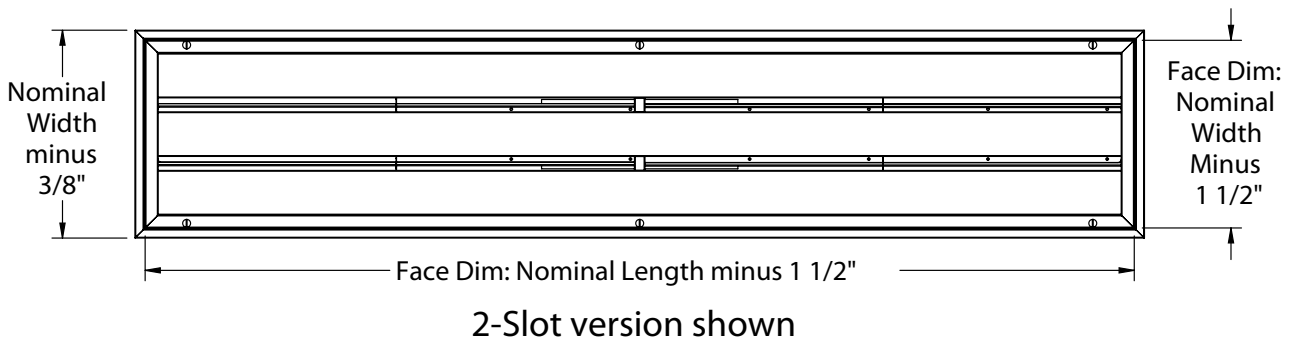

DIMENSIONS

Redefine your comfort zone.™ | www.titus-hvac.com

LINEATEC UNIT DIMENSIONS -MULTI-PIECE CONSTRUCTION

LineaTec - Side View

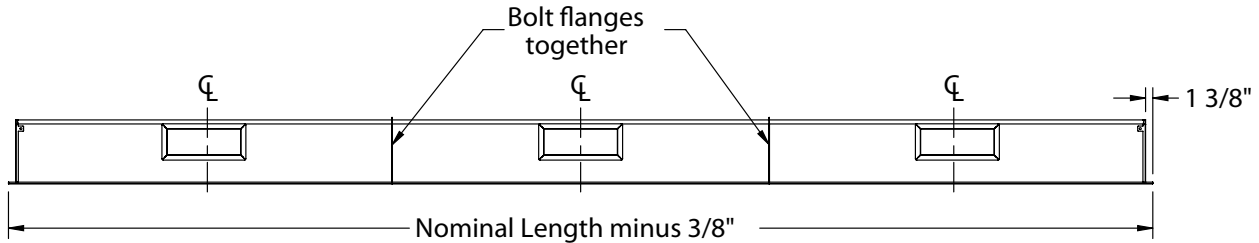

Note: Maximum single section length is 100"  
Inlets centered on section unless specified

LineaTec - End View

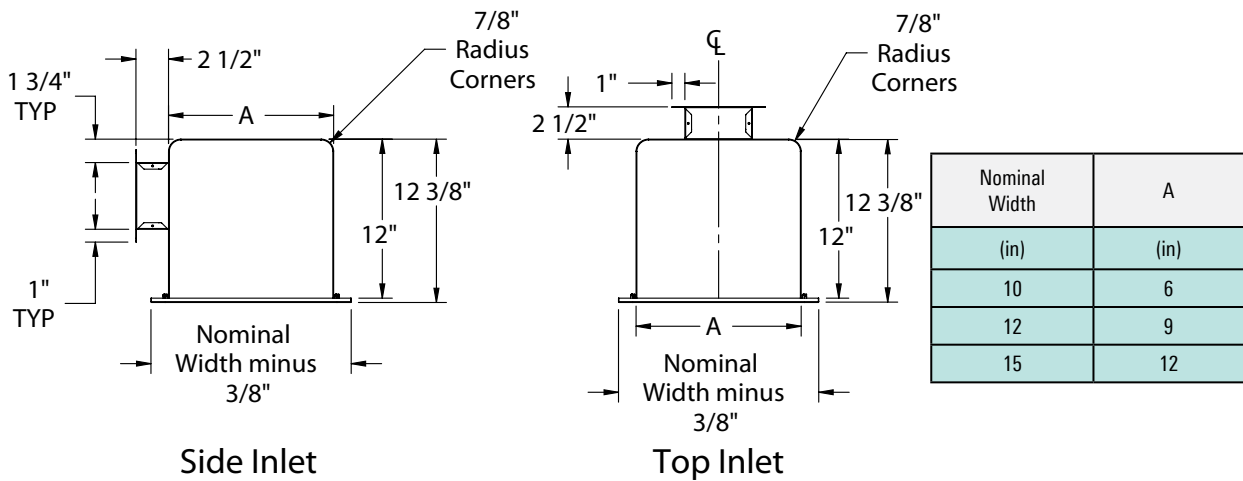

LineaTec - Face View

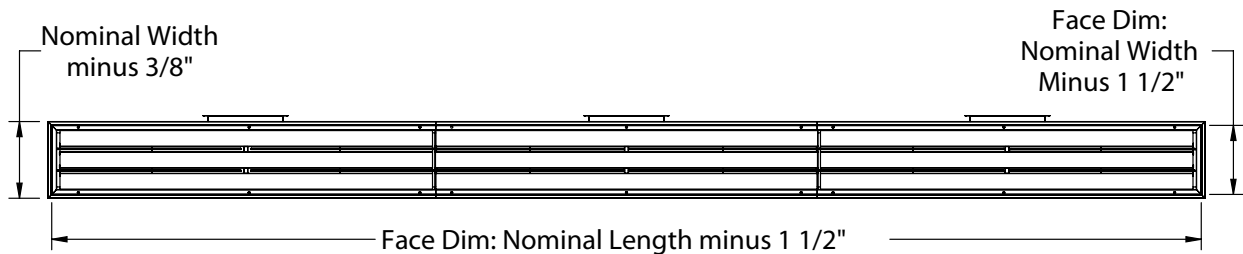

R

DIMENSIONS

LINEATEC UNIT DIMENSIONS - CONSTRUCTION DETAILS

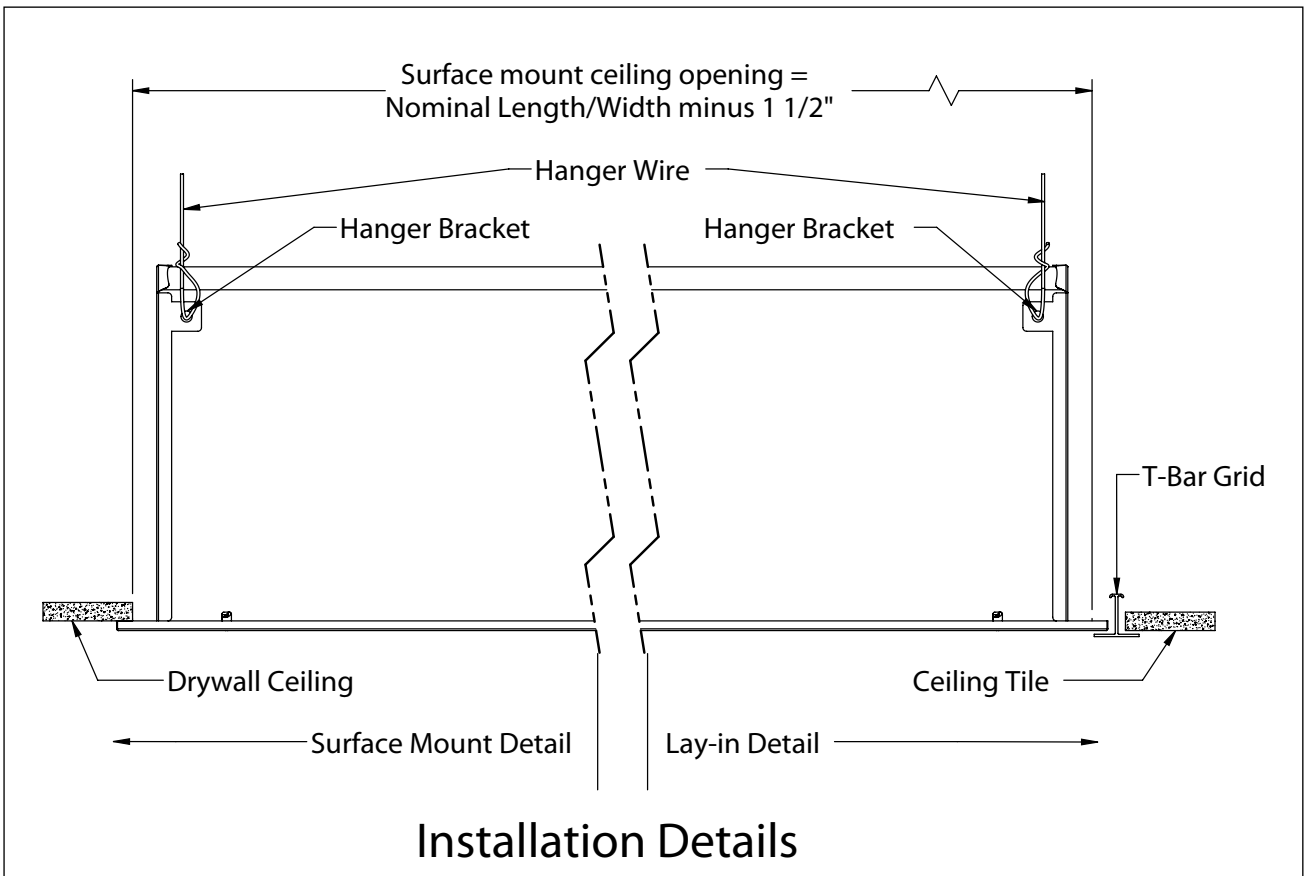
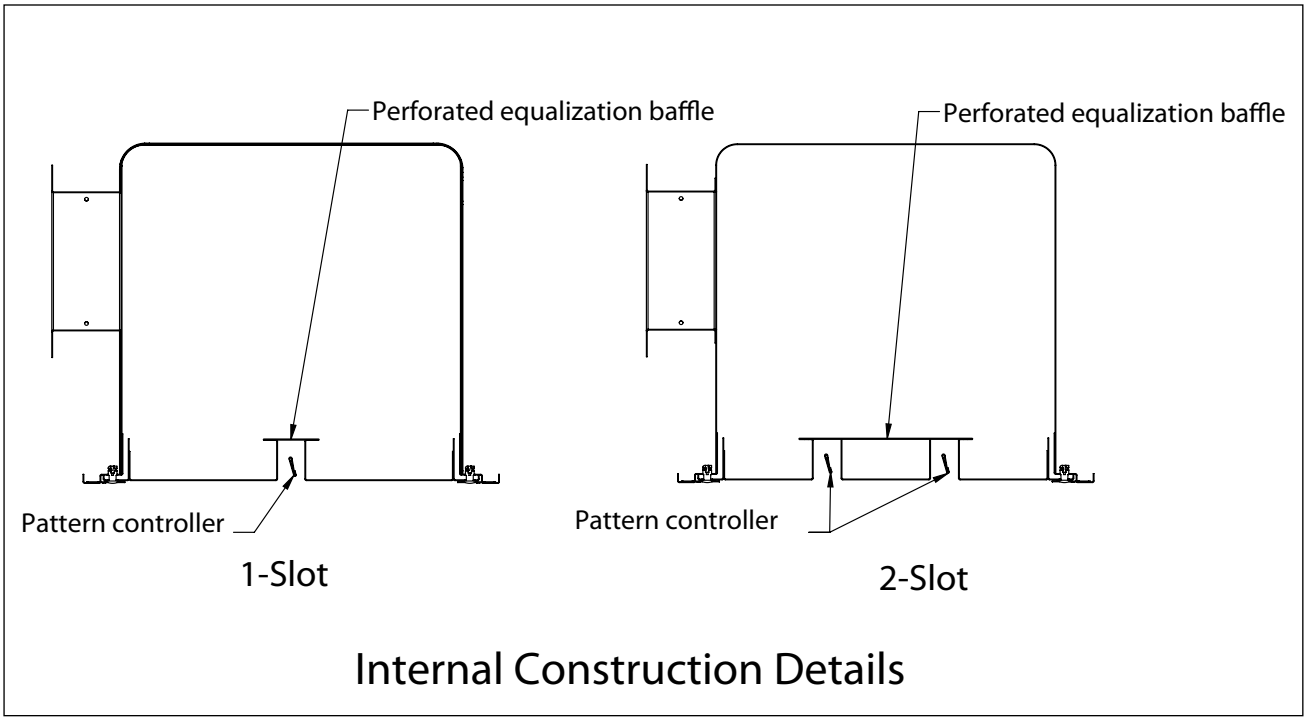

LINEATEC-AL AND LINEATEC-SS

	Airflow, cfm/Ft.	10	20	30	40	50	60	70
1-Slot	Static Pressure	0.004	0.015	0.034	0.061	0.095	0.136	0.186
	NC (Noise Criteria)	<10	<10	<10	<10	13	16	19
	Throw	0-1-3	1-3-6	3-4-7	4-6-8	5-6-9	6-7-10	6-7-11
	Airflow, cfm/Ft.	20	40	60	80	100	120	140
2-Slot	Static Pressure	0.004	0.015	0.034	0.061	0.095	0.136	0.186
	NC (Noise Criteria)	<10	<10	<10	19	26	31	37
	Throw	0-1-4	2-4-8	4-6-10	6-8-11	7-9-(13)	8-10-(14)	9-11-(15)
	Airflow, cfm/Ft.	20	40	60	80	100	120	140

- NC is based on a 6-foot unit
- Throw is based on isothermal air, vertical, in a room between 0 and 11 feet high, for 150, 100 and 50 fpm terminal velocities, for a 6-foot unit
- For cold air, throw will increase, heated air will not project as far as shown; See the section, Engineering Guidelines and the topic, 'Estimating Downward Vertical Projection' in this catalog for additional information
- Throw data included in () parenthesis is calculated to exceed floor to ceiling distance for the terminal velocities shown
- Static pressure shown assumes Titus recommended plenum
- Data is based on a factory provided plenum with 3/4" radiused corner and an 18" x 6" inlet

Redefine your comfort zone.™ | www.titus-hvac.com

R

PERFORMANCE DATA



## SteriTec

- Perforated pressure induction plate facilitates balancing
- Blades have minimum adjustability to allow precise control of the air curtain angle
- 2-slot or 1-slot configurations available
- May be mounted as surface mount or T-bar lay-in with support
- Available in square sizes from 8 x 8 feet through 20 x 20 feet as listed below. Rectangular sizes are also available.
- Other custom sizes are available
- Perimeter air curtain for creating an air wall between clean zones and adjacent area
- Face quickly removes for easy plenum access

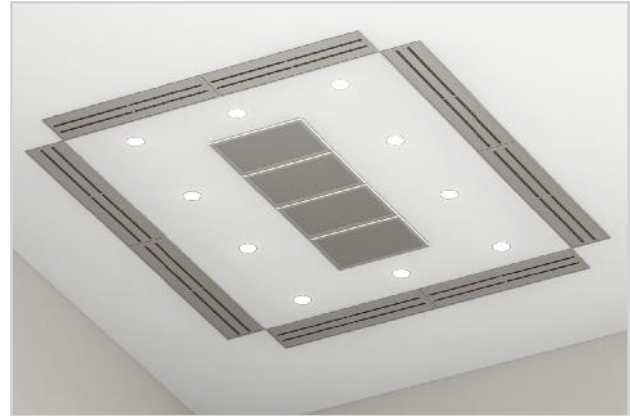

STERITEC

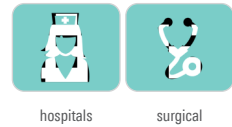

### MODELS:

SteriTec-AL / Aluminum  
SteriTec-SS / 304 Stainless Steel

### FINISHES:

Standard Finish - #26 White  
Optional Finish - #04 Mill

### OVERVIEW

#### Sterile Environment System Technology

According to ASHRAE Standard 170-2013 for hospital operating rooms, the laminar flow diffusers should be selected for an average velocity not to exceed 35 fpm at the operating table. This is about equal to the normal plume velocity emitted from the human body. This velocity can be calculated by taking airflow from the laminar flow diffusers and dividing this flow by the nominal face area of the diffusers. The size of the laminar flow field or many times called the "sterile field," should be at least the size of the operating table plus an additional area of 12 inches around the table. This is the absolute minimum size. However, many times additional equipment and tables are required and also need to be included in this sterile field. The sterile field should protect the patient and provide non-contaminated airflow protection for the patient, all equipment and personnel being used for the patient.

The terminal velocity of the laminar flow on the patient should not be greater than the plume velocity created by the normal human body at rest. This limitation is meant to stop the laminar flow from driving contamination into open wounds during surgery the plume velocity is approximately 25-35 fpm.

Ceiling area can be allowed in the sterile field for lighting and related services. Data has shown that if an air wall or air curtain like the SteriTec is used, room airflow entrainment is drastically reduced into

 See website for Specifications

the laminar flow sterile field with as much as 30% of the sterile field used for related services. Tests, conducted at the Titus laboratory, have shown the importance of this air wall or air curtain. If an air curtain is not used as shown for both a side view and a plan view contamination can and will be induced into the center of the sterile field. The migration of contamination has also been observed if the laminar diffusers are continuous over the operating room table and an air curtain has not been used. As shown, the inside edge of the SteriTec system air wall or air curtain should be mounted 18 to 30 inches outside the TLF generated nominal sterile field. The total airflow requirement varies with the room size. The required minimum airflow is 20 air changes per hour for operating rooms.

The side view of the SteriTec air curtain shows how this system stops room airflow induction into the laminar flow field at two very important locations. The first location is next to the ceiling. If the laminar flow is not continuous, and many times this is not the case due to lighting and gas columns etc., the air wall stops the induction along the ceiling line from being drawn into the laminar flow. The openings in the field can provide a material pathway for airflow to flow into the openings between the laminar flow diffusers. This then can allow secondary room airflow to flow into these areas which may be contaminated. The second area of protection is seen further down in the room. The SteriTec air curtain provides an invisible barrier or wall to reduce room air from being mixed with the pure filtered clean laminar flow from the TLF diffusers.

Contaminated air outside the air curtain is prevented from entraining or being mixed with the clean zone created and inside the LineaTec diffusers zone. In most applications the LineaTec diffusers of the SteriTec system are selected for a terminal velocity of 50 fpm about 2 Feet above the floor. This allows the flow to travel down to and along the floor to the external low sidewall exhaust return grilles.

The SteriTec system combines the features of the TLF and the LineaTec to form a clean zone within a cleanroom. A typical SteriTec system for an operating room includes a LineaTec perimeter air curtain and with TLF laminar flow TLF diffusers as the central supply air outlets. Return grilles are located at the low level sidewall as exhaust outlets on at least two of the room's walls. These are typically mounted so the lower portion of the grille frame is about 8 inches above the floor to allow cleaning of the room's floor.

### ADVANTAGES

- Available with optional 304 stainless steel or aluminum plenums
- Corner transitions are full plenum size creating no airflow restriction
- Available with round corners on plenums ( $7/8$ " radius)
- Continuous plenums minimize duct runs and facilitates self balancing
- Typical linear selection for 50 fpm terminal velocity 2 feet above floor

Nominal Sizes ft. "A" x "B"	Laminar Flow No. of Units & Sizes Units @ 30cfm/ft <sup>2</sup>		Linear Diffuser No. of Sections		Total		
			Side A	Side B	Laminar Flow cfm	LineaTec @ 40 cfm/ft cfm	cfm
8' x 8'	6-3x2	1080	2	2	1080	1280	2360
10' x 10'	8-2x4	1920	2	2	1,920	1,600	3,520
12' x 12'	8-2x4	1920	2	2	1,920	1,920	3,840
14' x 14'	10-2x4 2-2x6	3120	2	2	3,120	2,240	5,360
16' x 16'	10-2x4 2-2x6	3120	3	3	3,120	2,560	5,680
18' x 18'	18-2x4	4320	3	3	4,320	2,380	7,200
20' x 20'	32-2x4	7680	4	4	7,680	3,200	10,880

Note: Please check with your Titus representative before specifying sizes other than those listed above. Rectangular sizes are available.

No Air Curtain - Contamination - Not Blocked At Ceiling

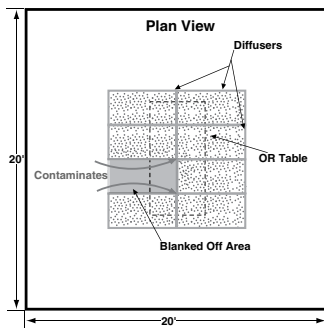

Laminar Flow With No Air Curtain

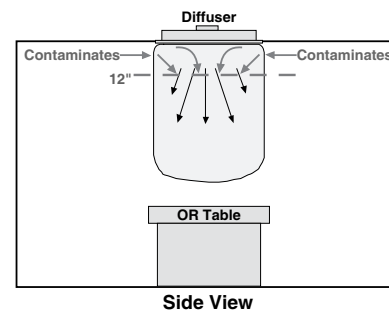

Laminar Flow With Air Curtain

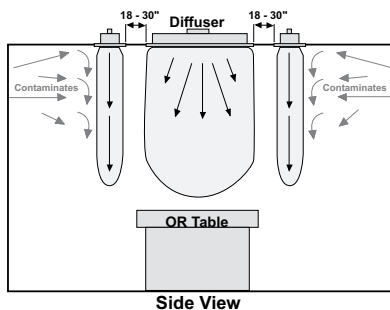

Air Curtain With Non-continuous Laminar Flow - Contamination Blocked

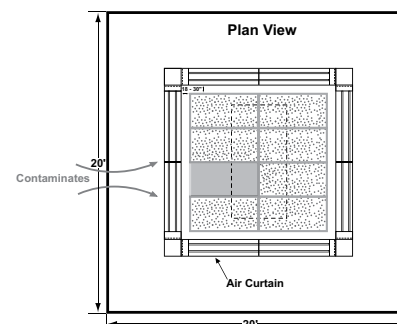



Material:

- SteriTec-AL  
Aluminum face with  
20-gauge aluminum plenum
- SteriTec-SS  
20-gauge 304 stainless steel  
face and plenums

Finish

- Standard Face Finish  
SteriTec-AL - #26 White Face  
SteriTec-SS - #04 Mill
- Standard Plenum Finish  
Optional Finish - #04 Mill

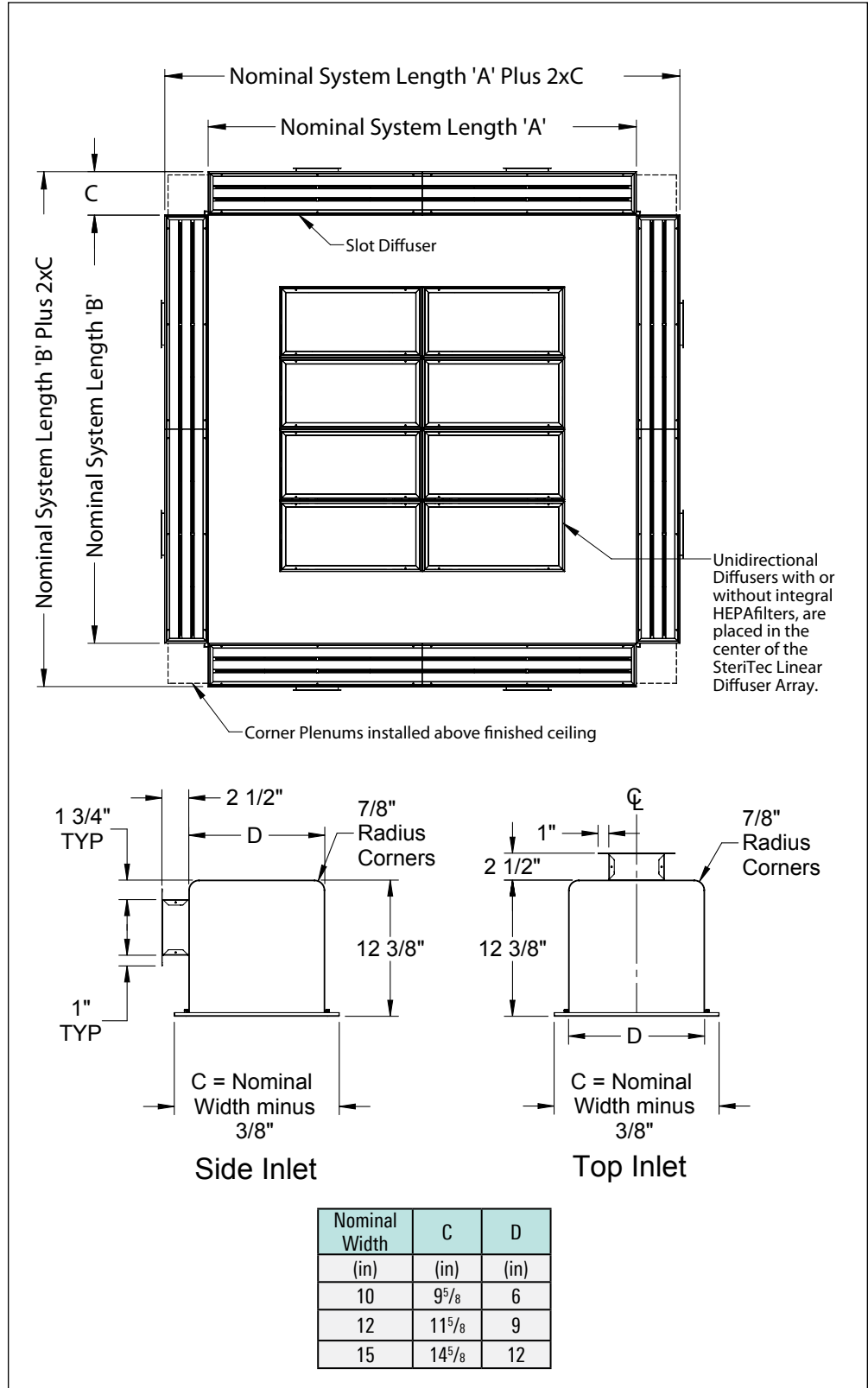

## DIMENSIONS

## critical environment diffusers

### PLENUMS INCLUDE:

- 7/8" radius on horizontal plenum corners (inlet does not have radius)
- Continuously welded seams ground smooth to make hand cleaning easy
- Corners have no crevices on radiused plenums to trap contaminants or mold
- Plenums have heavy duty hanger brackets for suspending the entire system from the structure
- Multi-section plenums bolt together using heavy duty flanges

### NOMINAL PLENUM LENGTHS

Note: Use the chart shown at right for identifying nominal plenum section lengths by system size.

Top View - 8 x 8 feet, 10 x 10 feet, 12 x 12 feet Systems

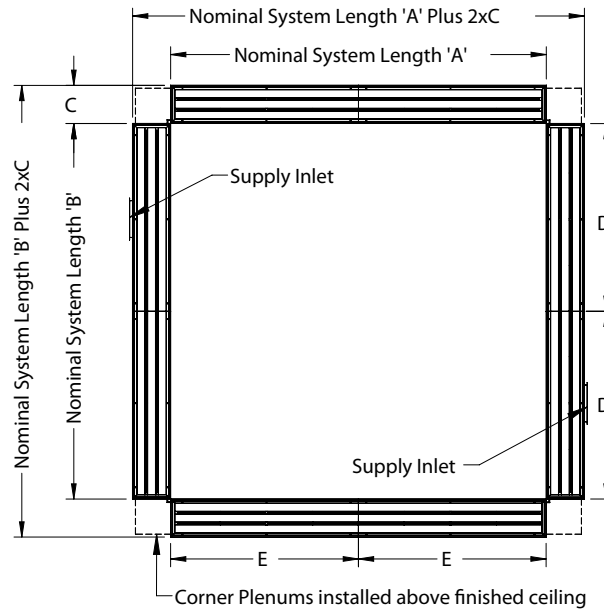

System Nominal Size (ft)	Nominal Plenum Length (ft)	
	D	E
8 x 8	4	4
10 x 10	5	5
12 x 12	6	6
14 x 14	4 <sup>2</sup> / <sub>3</sub>	5
16 x 16	5 <sup>1</sup> / <sub>3</sub>	5
18 x 18	6	6

Rectangular sizes are available

Top View - 14 x 14 feet, 16 x 16 feet, 18 x 18 feet Systems

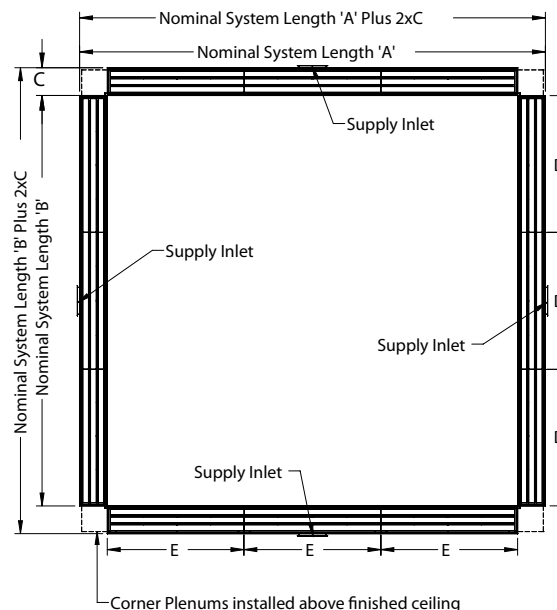

All dimensions are in inches

NOMINAL PLENUM LENGTHS

Note: Use the chart shown at right for identifying nominal plenum section lengths by system size.

FLANGE AND HANGER BRACKET DETAILS

Note: All systems must be suspended by wire whether surface mount or lay-in.

System Nominal Size (ft)	Nominal Plenum Length (ft)	
	D	E
20 x 20	5'	5'

Top View - 20' x 20', 22' x 22', 24' x 24' Systems

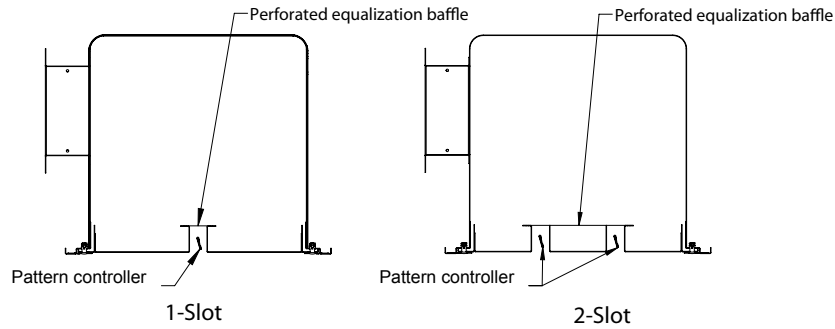
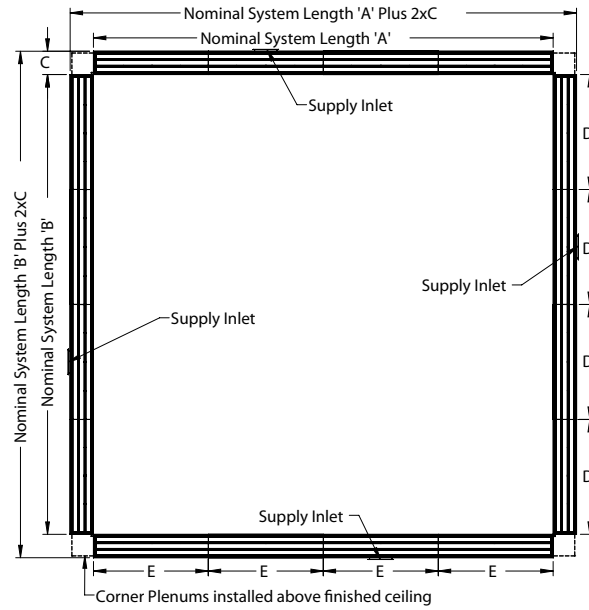

Internal Construction Details

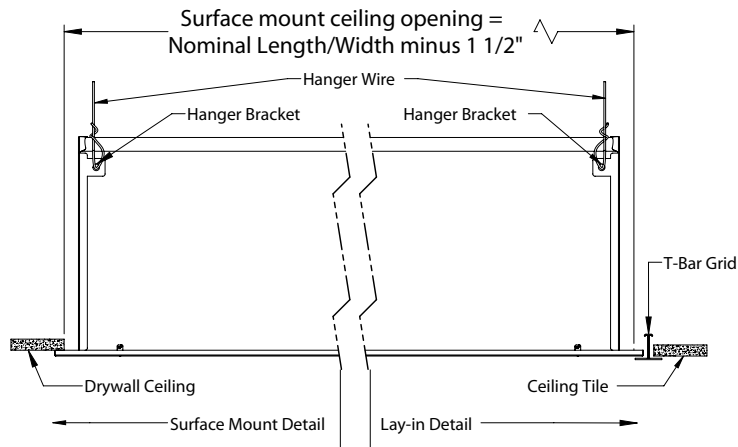

Installation Details

All dimensions are in inches

### PLENUM INLET LOCATIONS

Note: Inlets should be of equal size. Maximum inlet size is 8 inches tall by the section length minus 12 inches. Inlet velocity should be kept to less than 800 fpm, preferably less than 500 fpm.

System Layout A - Top View

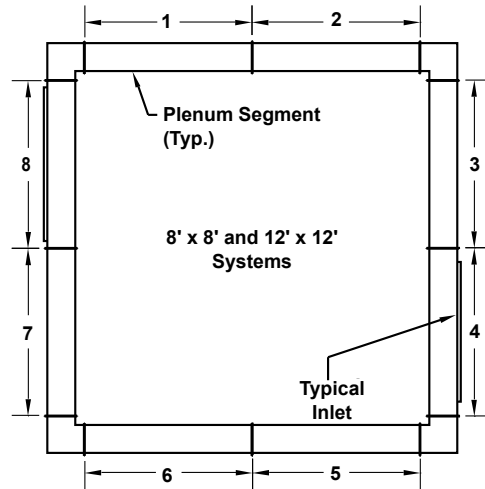

System Layout B - Top View

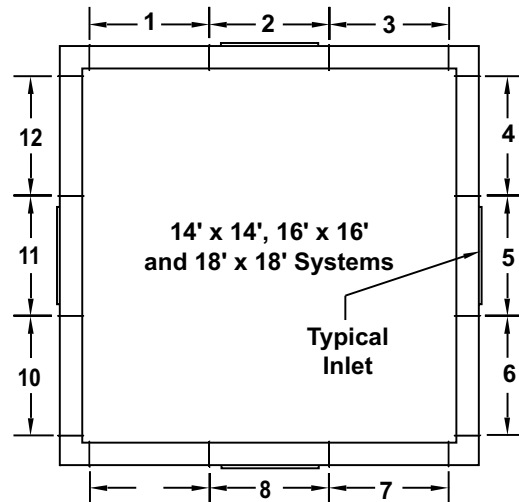

System Layout C - Top View

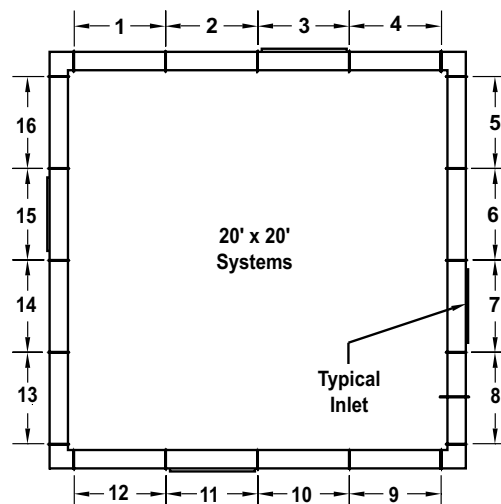

## Operating Room Ceiling System

## critical environment diffusers

### AORCS

- Heavy duty extruded aluminum construction
- All systems are custom engineered for each installation & application
- Closed-cell polyethylene gasket with pressure sensitive adhesive
- Pre-cut at factory for rapid assembly in the field with "quick snap" connectors
- "Quick snap" connectors allow for reconfiguration in the field
- Factory supplied blank-off panels to match air distribution equipment

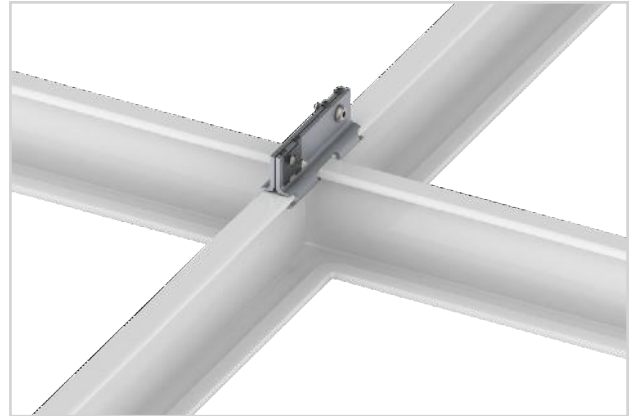

AORCS



hospitals

surgical

### MODEL:

AORCS / Aluminum 1½" Adjustable Grid System

### FINISHES:

Standard Finish - #26 White / Antimicrobial PowderCoat

Optional Finish - #01 Mill

Optional Finish - #21 Enviro-Thane to match / Antimicrobial PowderCoat

Optional Finish - #84 Black / Antimicrobial PowderCoat

### OVERVIEW

#### Gasketed Heavy Duty Ceiling Grid System

The Atlas Ceiling Grid System is a field assembled, gasketed, heavy duty ceiling grid for use in operating rooms, laboratories, and cleanroom applications. Used to support diffusers, blank-off panels, and light fixtures, the Atlas ceiling system also creates an air tight barrier between the space and ceiling plenum to prevent transmission of contaminants into or out of the occupied space. All systems are custom engineered for each unique application.



See website for Specifications

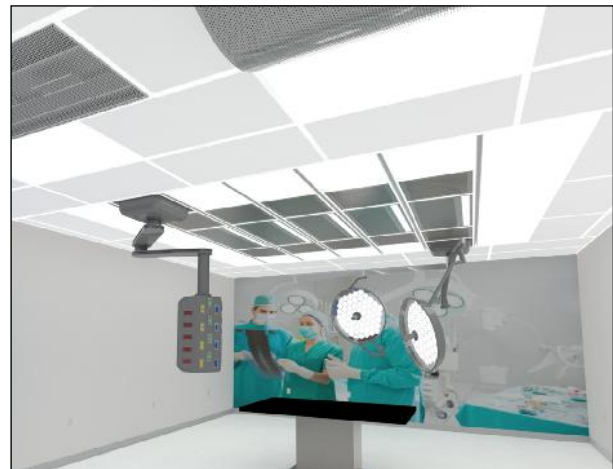

AORCS rendering showcases the new ceiling grid system



Framed panel



Solid panel

AORCS UNIT DIMENSIONS

Top View

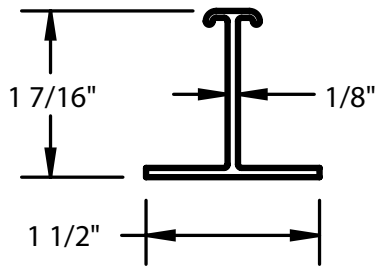

Full Tee

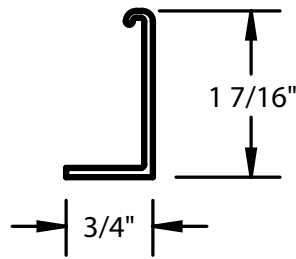

Half Tee

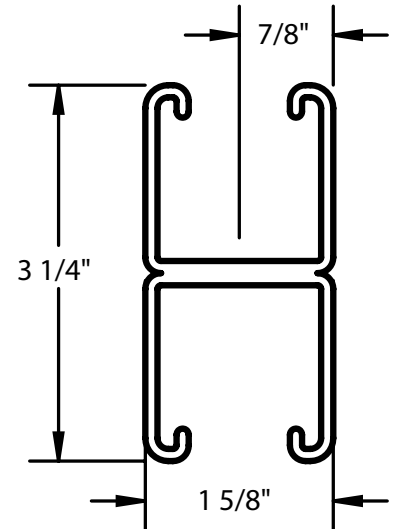

Unistrut®

Example Layout

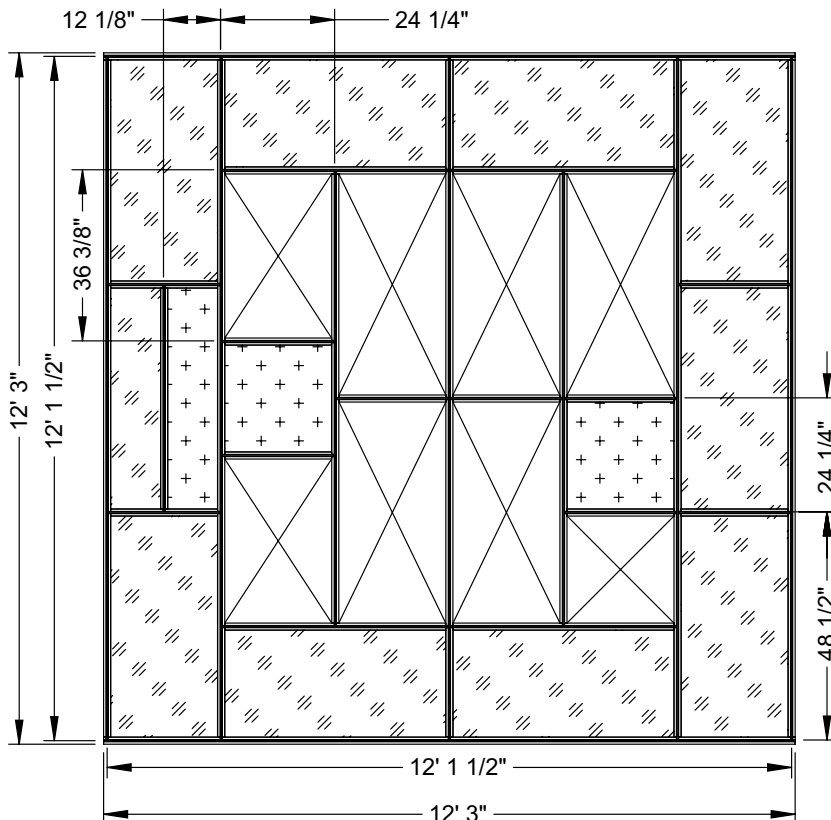

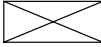
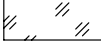
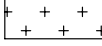
-  Unidirectional Diffusers
-  Lighting
-  Blank-off panels

## NEXUS OR SUITE

- Integrated air distribution and lighting system
- Delivers clean air and quality lighting while maximizing space and performance
- Laminar air diffusers protect patient from contaminated air
- Direct, high-output OR-grade lighting does not interfere with the air stream
- Customizable system utilizes common, low-profile plenum to allow quick and easy installation
- Simplifies compliance with ASHRAE 170 – Ventilation in Health Care Facilities

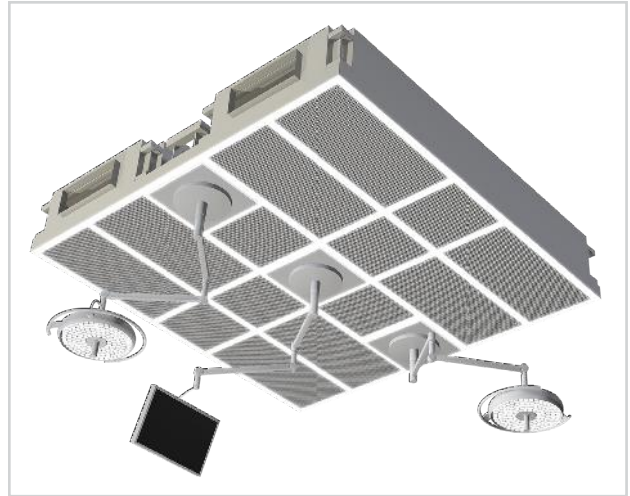

NEXUS OR SUITE-S  
HEAVY-DUTY MODEL



hospitals

surgical

### MODEL:

Nexus OR Suite/Standard Construction  
Nexus OR Suite-S/Heavy-Duty Construction

### OPTIONS:

Virtually unlimited layout options and combinations of airflow diffusers, gel-seal HEPA or ULPA filters, white lighting, green lighting, and CRI (Color Rendering Index) or R9 lighting.

### OVERVIEW

The Nexus OR Suite connects air, light, and more, to deliver clean air and quality lighting, while maximizing space and performance in operating rooms. This customizable system utilizes a common, low-profile plenum to allow quick and easy installation in new construction or retrofit applications. The Nexus OR Suite has been specifically designed to make the best use of the limited ceiling space by integrating OR-grade LED lighting within laminar airflow diffusers. In doing so, it helps comply with ASHRAE 170's requirements for air changes and velocity. It is available in two models, a standard and heavier-duty model that can accommodate a wide range of suspended equipment, including all necessary lighting and booms.



See website for Specifications



NEXUS OR SUITE  
STANDARD MODEL

## Fan Filter Diffusers

## critical environment diffusers

### Fan Filter Diffusers

- Low profile design
- PSC or ECM motor
- Forward curved or backward curved fan
- Solid state, visual, or infrared speed control
- Walkable plenum (excluding prefilter)
- UL listed (120V, 277V)
- Standard sizes: 24" x 24" and 48" x 24"
- Aluminum construction (stainless steel optional)
- Options: Duct collar, challenge port, ULPA filter, power cord

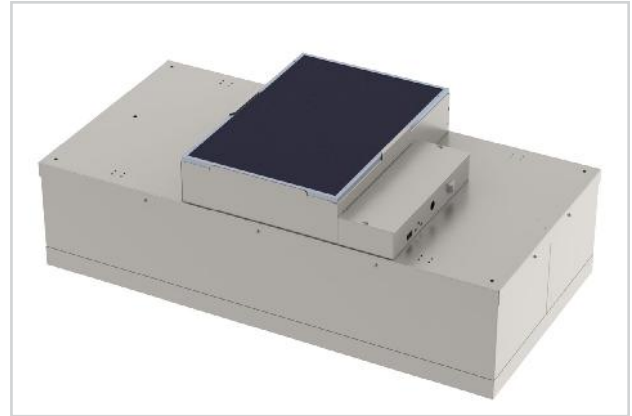

FAN FILTER DIFFUSERS



cleanrooms

research labs



See website for Specifications

### MODELS:

FFD / PSC motor / HEPA Filter  
 FFDE / ECM motor / HEPA Filter  
 FFDB / ECM motor / Backward curved fan / HEPA Filter  
 FFDR / PSC motor / Room side replaceable HEPA Filter  
 FFDER / ECM motor / Room side replaceable HEPA Filter  
 FFDBR / ECM motor / Room side replaceable HEPA filter  
 FFDRRA / Room side replaceable PSC motor and HEPA Filter  
 FFDERA / Room side replaceable ECM motor and HEPA Filter  
 FFDBRA / Room side replaceable ECM motor and HEPA filter

### OVERVIEW

Fan filter diffusers provide a unique solution in cleanroom applications. In situations where the use of conventional ducted modules is impractical or the air supply has insufficient static pressure to move the air through a HEPA filter, fan filter diffusers provide an excellent alternative. In cleanroom design, the primary factor is contaminant removal and the cleanliness level, so moving the air is a major challenge. The volume of recirculated HEPA filtered air, including conditioned air to handle high cooling loads that are typical of many cleanrooms, can range from less than twenty to more than five hundred air changes per hour. Fan filter diffusers provide a constant flow of clean air into the space which prevents the infiltration of contaminants and provides for the removal of particles generated by people and equipment in the work space.

### TITUS FAN FILTER DIFFUSERS...LOW ENERGY, LOW SOUND AND LOW PROFILE

Titus offers a complete line of fan filter diffusers that can be used for new design or retrofitting cleanroom environments. Each Titus FFD (fan filter diffuser) is a self-contained fan filter module that includes HEPA filter, pre-filter, fan speed control and low profile design. Air circulation is maintained by using a lightweight, forward curved fan powered by

a 120V or 277V, 60Hz motor. Motor speed is adjusted by the solid-state speed control mounted on top of the housing. Patented baffling technology ensures uniform airflow across the filter face and attenuates sound for one of the quietest fan filter diffusers in the industry. The room side replaceable option (R) provides quick and efficient replacement of the HEPA or ULPA filter from room side while the diffuser remains in place. The room side replaceable option (RA) allows for replacement of the motor and filter from the room side.

Titus fan filter diffusers are also available with an ECM brushless DC motor. These units dynamically adjust themselves to maintain the set airflow, compensating for changes in static pressure, filter loading or other local conditions. Titus fan filter diffusers with ECM can easily maintain cleanroom air levels exceeding IEST recommended practices. Airflow is maintained so constantly and consistently that the need for future balancing is greatly reduced. The ECM option, along with the patented baffling system and forward curve fan, makes Titus fan filter diffusers intelligent, energy efficient and ultra quiet.



FFD / FFDR / FFDR

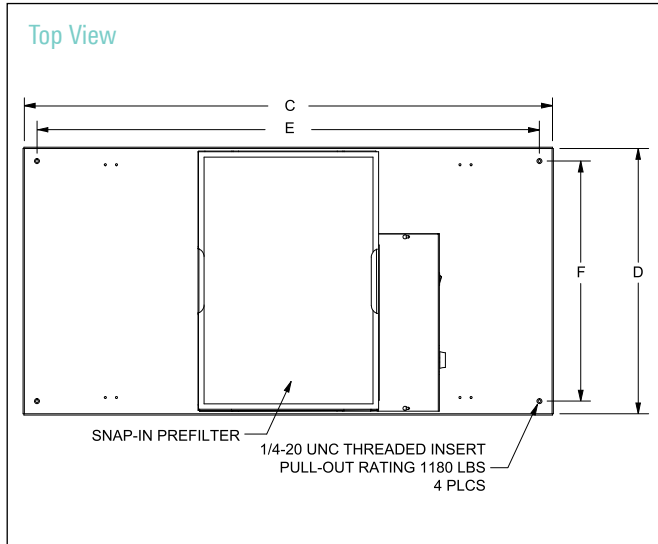
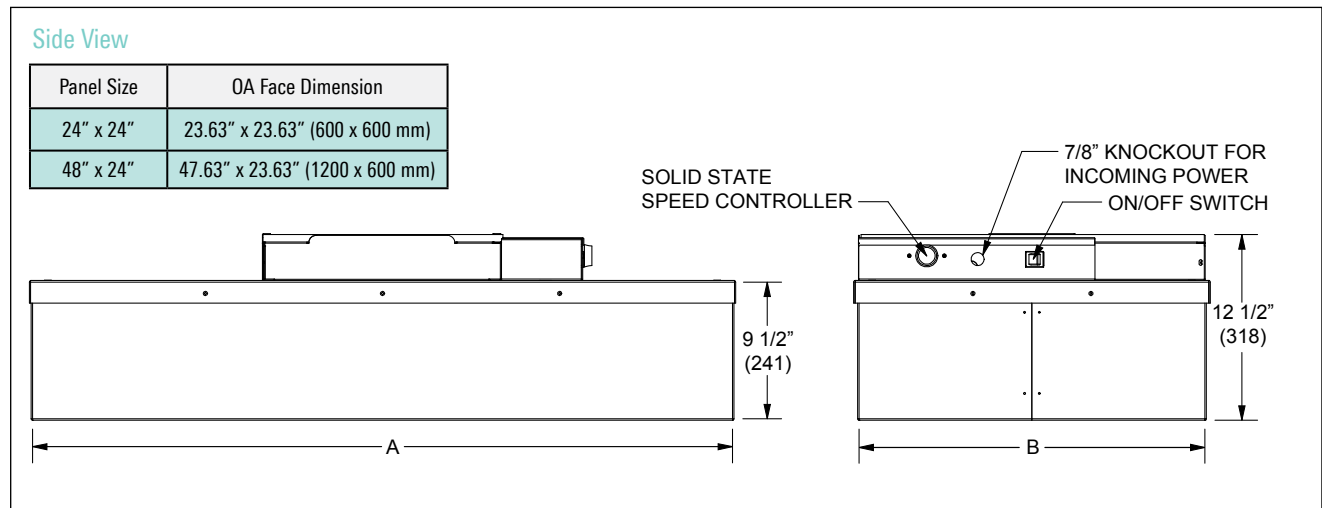

TABLE 1

	A	B	C	D	E	F
	In (mm)	In (mm)	In (mm)	In (mm)	In (mm)	In (mm)
24" x 24"	23 <sup>5</sup> / <sub>8</sub>	23 <sup>5</sup> / <sub>8</sub>	23 <sup>11</sup> / <sub>32</sub>	23 <sup>11</sup> / <sub>32</sub>	23 <sup>3</sup> / <sub>8</sub>	23 <sup>3</sup> / <sub>8</sub>
	(600)	(600)	(606)	(606)	(543)	(543)
48" x 24"	47 <sup>5</sup> / <sub>8</sub>	23 <sup>5</sup> / <sub>8</sub>	47 <sup>11</sup> / <sub>32</sub>	23 <sup>11</sup> / <sub>32</sub>	45 <sup>3</sup> / <sub>8</sub>	21 <sup>3</sup> / <sub>8</sub>
	(1200)	(600)	(1215)	(606)	(1152)	(543)

FFD



FFDR / FFDR

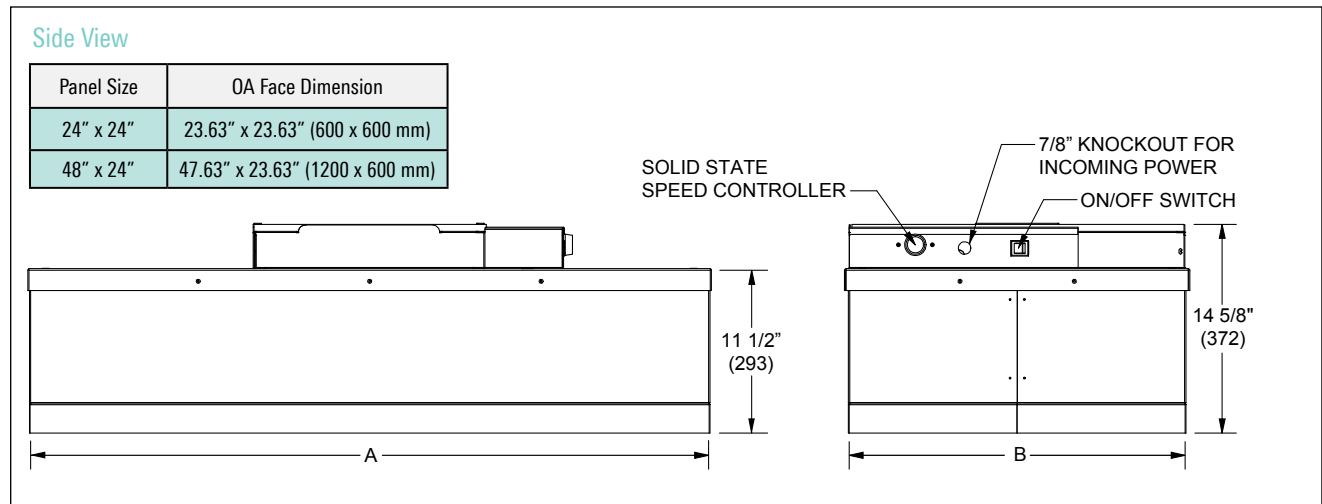

All dimensions are in inches

FFDE / FFDB / FFDER / FFDBR / FFDERA / FFDBRA

TABLE 2

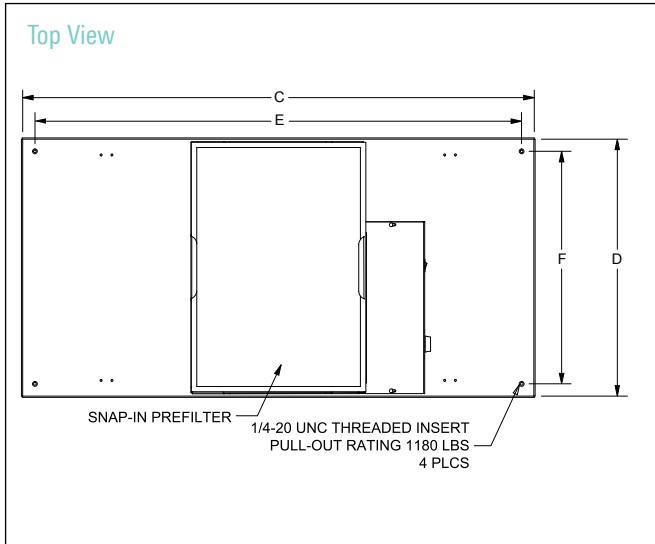

	A	B	C	D	E	F
	In (mm)	In (mm)	In (mm)	In (mm)	In (mm)	In (mm)
24" x 24"	23 <sup>5</sup> / <sub>8</sub> (600)	23 <sup>5</sup> / <sub>8</sub> (600)	23 <sup>11</sup> / <sub>32</sub> (606)	23 <sup>11</sup> / <sub>32</sub> (606)	23 <sup>3</sup> / <sub>8</sub> (543)	23 <sup>3</sup> / <sub>8</sub> (543)
48" x 24"	47 <sup>5</sup> / <sub>8</sub> (1200)	23 <sup>5</sup> / <sub>8</sub> (600)	47 <sup>11</sup> / <sub>32</sub> (1215)	23 <sup>11</sup> / <sub>32</sub> (606)	45 <sup>3</sup> / <sub>8</sub> (1152)	21 <sup>3</sup> / <sub>8</sub> (543)

FFDE / FFDB

Side View

Panel Size	OA Face Dimension
24" x 24"	23.63" x 23.63" (600 x 600 mm)
48" x 24"	47.63" x 23.63" (1200 x 600 mm)

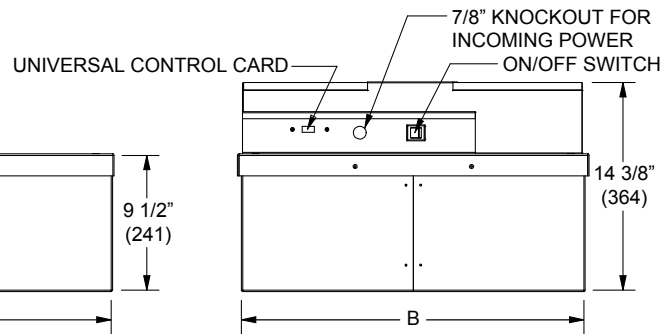
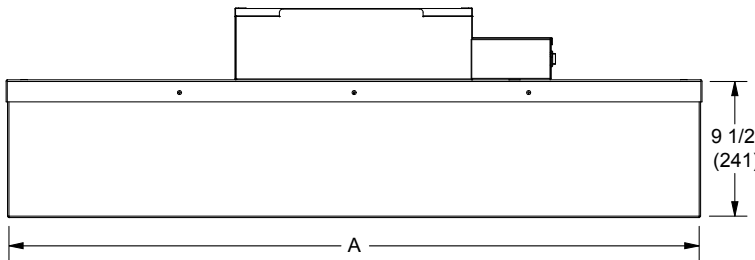

FFDER / FFDBR / FFDERA / FFDBRA

Side View

Panel Size	OA Face Dimension
24" x 24"	23.63" x 23.63" (600 x 600 mm)
48" x 24"	47.63" x 23.63" (1200 x 600 mm)

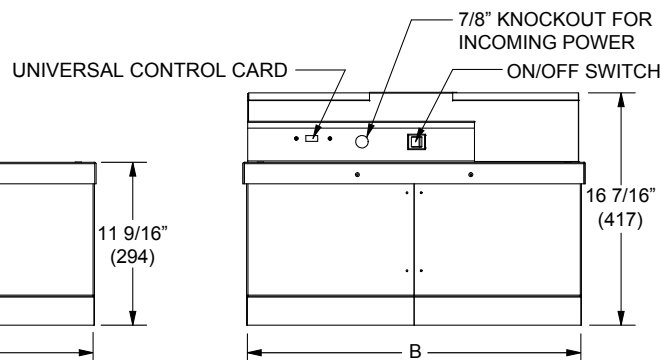
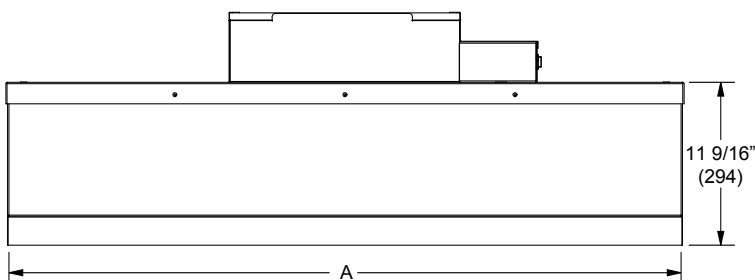

FFD / FFDE / FFDB

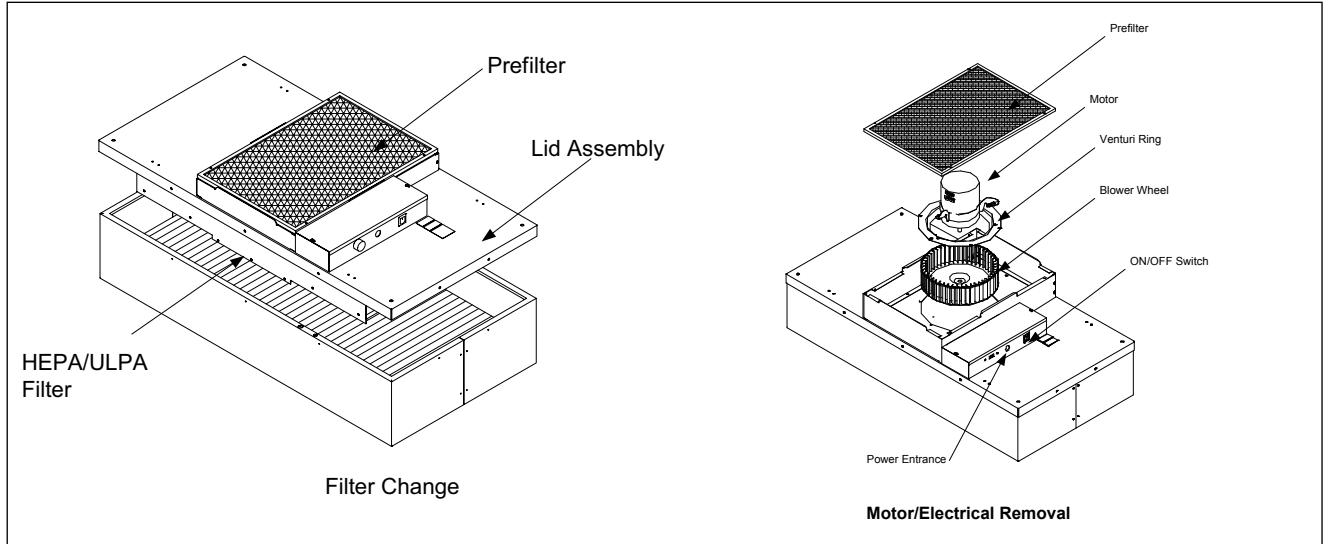

FFDR / FFDER / FFDBR

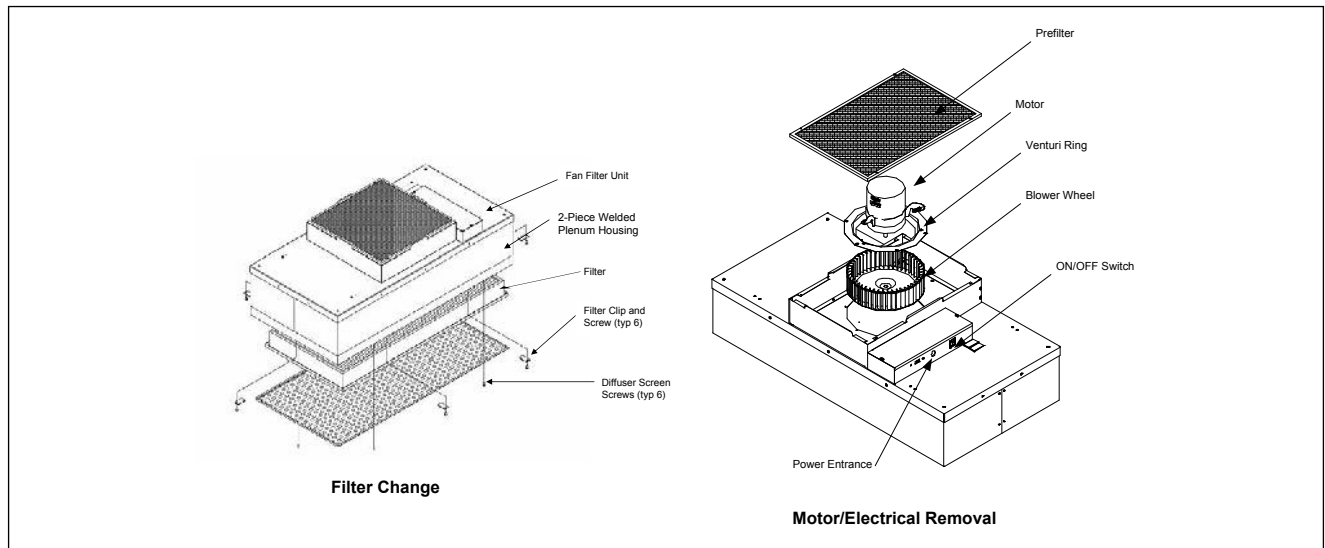

FFDRA / FFDERA / FFDBRA

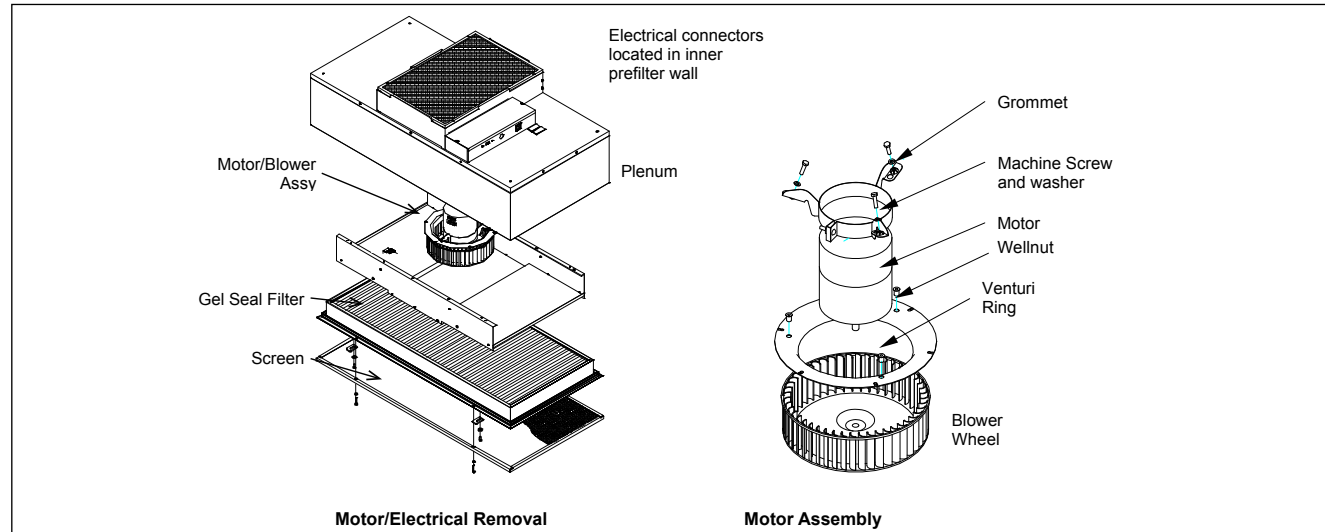

FILTER & GEL SEAL DETAIL

Lower housing is welded with full penetration welds providing a leak free mate to the gel seal filter. No caulk is required.



FFD / FFDE

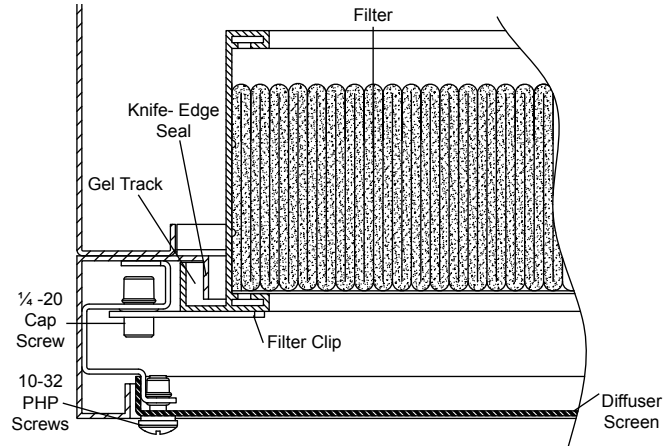

FFDR / FFDER / FFDR / FFDERA

CHALLENGE & COLLABORATION PORT DETAIL

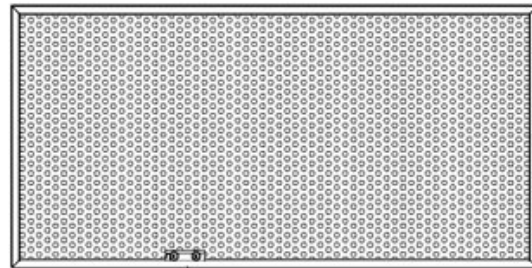
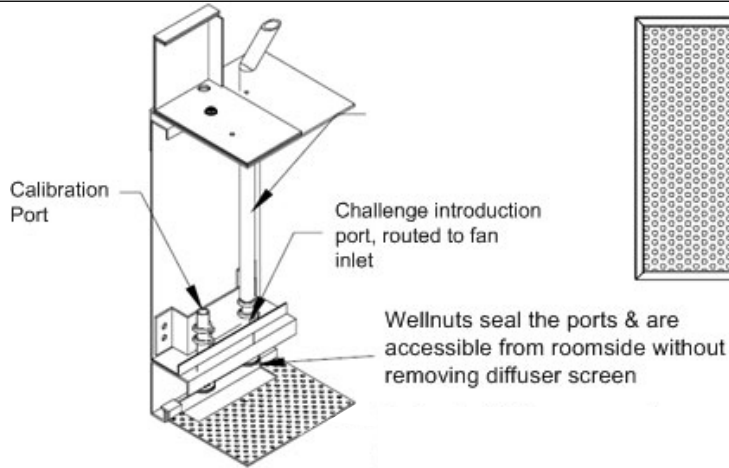

standard  
models.

ARRAY VIEW

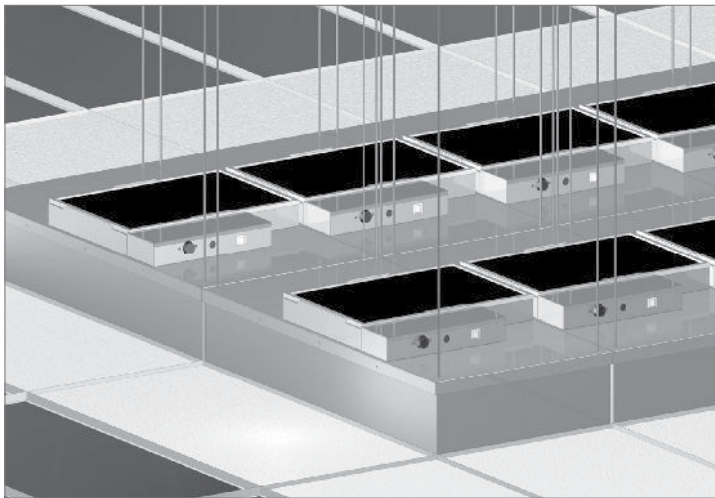

*NOTES: Shown left is a typical installation of multiple fan filter units mounted above the service area, completely blanketing the critical area with clean, filtered supply air. For spot applications, a single fan filter unit can be mounted over a work bench or table to reduce particulate counts.*

FFD / FFDR / FFDR A

Unit Type	Nominal Unit Sizes	Motor Hp	Max CFM	CFM @ 90 fpm	Watts @ Max CFM	Watts @ 90 fpm	Total Unit Weight (lbs)		Sound Level dB @90 fpm	Octave Band Sound @ 90fpm					
							AL	SS		2	3	4	5	6	7
							FFD	24" x 24"		1/4	410	315	200	165	41
36" x 24"	560	470	270	240	52	62		41	42		41	44	30	22	14
48" x 24"	660	650	315	310	66	76		51	57		52	49	44	36	30
FFDR	24" x 24"	1/4	350	210	170	140	44	54	48	45	51	49	36	32	25
	36" x 24"		500	340	250	200	54	64	41	52	41	42	25	17	10
	48" x 24"		610	470	300	245	71	81	51	57	52	49	44	36	30
FFDR A	24" x 24"	1/4	350	210	170	140	44	54	48	45	51	49	36	32	25
	36" x 24"		500	340	250	200	54	64	41	52	41	42	25	17	10
	48" x 24"		610	470	300	245	71	81	51	57	52	49	44	36	30

Notes: Performance tested in accordance with ANSI/AMCA 210-07 and ANSI/ASHRAE 51-07 test standards for Certified Aerodynamic Performance Rating  
 90 fpm values are based on active filter face area  
 Heat gain: BTU = Watts x 3.413

FFDE / FFDER / FFDER A

Unit Type	Nominal Unit Sizes	Motor Hp	Max CFM	CFM @ 90 fpm	Watts @ Max CFM	Watts @ 90 fpm	Total Unit Weight (lbs)		Sound Level dB @90 fpm	Octave Band Sound @ 90fpm					
							AL	SS		2	3	4	5	6	7
							FFDE	24" x 24"		1/3	410	315	145	85	41
36" x 24"	560	470	200	140	52	62		47	40		42	42	33	25	16
48" x 24"	660	650	260	235	66	76		48	46		50	47	40	38	35
FFDER	24" x 24"	1/3	350	210	130	50	44	54	46	48	48	49	44	38	30
	36" x 24"		500	315	190	85	54	64	47	39	40	38	27	19	11
	48" x 24"		610	470	225	110	71	81	48	46	50	47	40	38	35
FFDER A	24" x 24"	1/3	350	210	130	50	44	54	46	46	48	49	44	38	30
	36" x 24"		500	315	190	85	54	64	47	39	40	38	27	19	11
	48" x 24"		610	470	225	110	71	81	48	46	50	47	40	38	35

Notes: Performance tested in accordance with ANSI/AMCA 210-07 and ANSI/ASHRAE 51-07 test standards for Certified Aerodynamic Performance Rating  
 90 fpm values are based on active filter face area  
 Heat gain: BTU = Watts x 3.413



PERFORMANCE DATA

critical environment diffusers

Redefine your comfort zone.™ | www.titus-hvac.com

FFDB / FFDBR / FFDBRA

Unit Type	Nominal Unit Sizes	Motor Hp	Max CFM	CFM @ 90 fpm	Watts @ Max CFM	Watts @ 90 CFM	Total Unit Weight (lbs)		Sound Level dB @90 fpm	Octave Band Sound @ 90fpm					
							AL	SS		2	3	4	5	6	7
FFDB	24" x 24"	1/3	410	315	145	85	41	51	46	39	41	40	35	32	19
	24" x 36"		650	470	150	65	52	62	47	53	52	46	37	30	20
	24" x 48"		950	650	250	90	66	76	52	58	58	50	43	33	25
FFDBR	24" x 24"	1/3	350	210	130	50	44	54	46	42	42	40	33	28	17
	24" x 36"		650	340	150	45	54	64	43	48	45	44	31	20	12
	24" x 48"		850	477	240	65	71	81	47	53	53	45	35	23	20
FFDBRA	24" x 24"	1/3	350	210	130	50	44	54	46	42	42	40	33	28	17
	24" x 36"		650	340	150	45	54	64	43	48	45	44	31	20	12
	24" x 48"		850	477	240	65	71	81	47	53	53	45	35	23	20

Notes: Performance tested in accordance with ANSI/AMCA 210-07 and ANSI/ASHRAE 51-07 test standards for Certified Aerodynamic Performance Rating  
 90 fpm values are based on active filter face area  
 Heat gain: BTU = Watts x 3.413

FULL LOAD AMPS

PSC	115V	2.70
	208V	1.30
	277V	1.20
ECM	115V	4.50
	208V	2.80
	277V	2.30

ACTIVE FILTER FACE AREA

Unit Type	Nominal Unit Size	Active Filter Face Area (ft <sup>2</sup> )
FFD / FFDE / FFDB	24" x 24"	3.5
	36" x 24"	5.3
	48" x 24"	7.2
FFDR / FFDR / FFDBR FFDER / FFDERA / FFDBRA	24" x 24"	2.3
	36" x 24"	3.8
	48" x 24"	5.3

R

PERFORMANCE DATA

HEPA FILTER

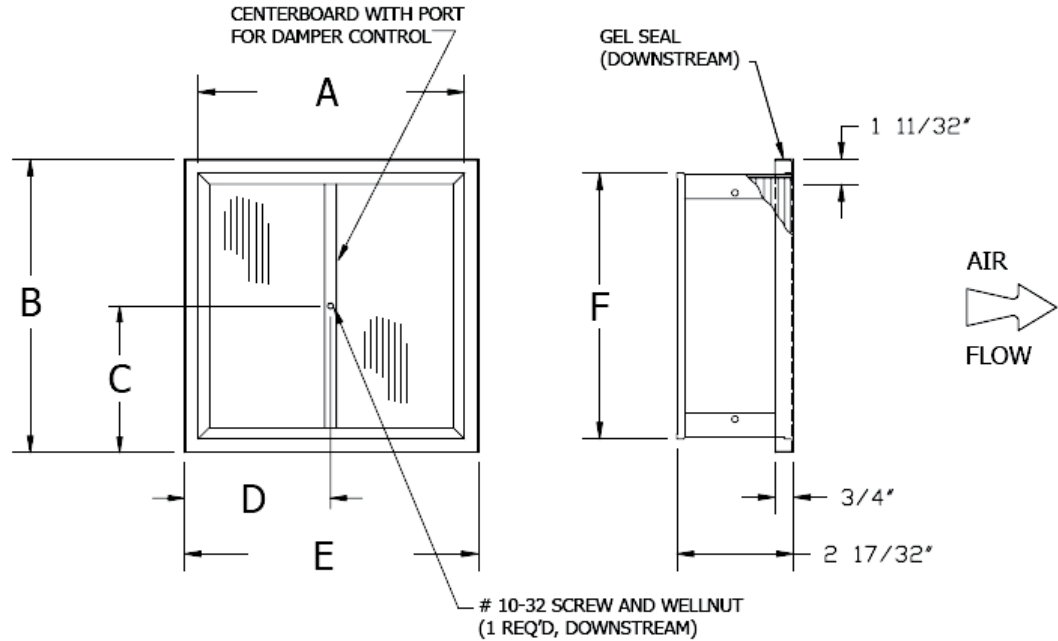

Filter Part Number	Nominal Size	A	B	C	D	E	F	Effective Face Area (Sq ft)
HF2412T	24 X 12	16 <sup>3</sup> / <sub>4</sub>	6 <sup>1</sup> / <sub>8</sub>	3 <sup>1</sup> / <sub>16</sub>	9 <sup>1</sup> / <sub>16</sub>	18 <sup>1</sup> / <sub>8</sub>	4 <sup>3</sup> / <sub>4</sub>	0.37
HF3612T	36 X 12	28 <sup>3</sup> / <sub>4</sub>	6 <sup>1</sup> / <sub>8</sub>	3 <sup>1</sup> / <sub>16</sub>	15 <sup>1</sup> / <sub>16</sub>	30 <sup>1</sup> / <sub>8</sub>	4 <sup>3</sup> / <sub>4</sub>	0.66
HF4812T	48 X 12	40 <sup>3</sup> / <sub>4</sub>	6 <sup>1</sup> / <sub>8</sub>	3 <sup>1</sup> / <sub>16</sub>	21 <sup>1</sup> / <sub>16</sub>	42 <sup>1</sup> / <sub>8</sub>	4 <sup>3</sup> / <sub>4</sub>	0.94
HF6012T	60 X 12	52 <sup>3</sup> / <sub>4</sub>	6 <sup>1</sup> / <sub>8</sub>	3 <sup>1</sup> / <sub>16</sub>	27 <sup>1</sup> / <sub>16</sub>	54 <sup>1</sup> / <sub>8</sub>	4 <sup>3</sup> / <sub>4</sub>	1.23
HF7212T	72 X 12	64 <sup>3</sup> / <sub>4</sub>	6 <sup>1</sup> / <sub>8</sub>	3 <sup>1</sup> / <sub>16</sub>	33 <sup>1</sup> / <sub>16</sub>	66 <sup>1</sup> / <sub>8</sub>	4 <sup>3</sup> / <sub>4</sub>	1.52
HF2424T	24 x 24	16 <sup>3</sup> / <sub>4</sub>	18 <sup>1</sup> / <sub>8</sub>	9 <sup>1</sup> / <sub>16</sub>	9 <sup>1</sup> / <sub>16</sub>	18 <sup>1</sup> / <sub>8</sub>	16 <sup>3</sup> / <sub>4</sub>	1.66
HF3624T	36 x 24	28 <sup>3</sup> / <sub>4</sub>	18 <sup>1</sup> / <sub>8</sub>	9 <sup>1</sup> / <sub>16</sub>	15 <sup>1</sup> / <sub>16</sub>	30 <sup>1</sup> / <sub>8</sub>	16 <sup>3</sup> / <sub>4</sub>	2.94
HF4824T	48 x 24	40 <sup>3</sup> / <sub>4</sub>	18 <sup>1</sup> / <sub>8</sub>	9 <sup>1</sup> / <sub>16</sub>	21 <sup>1</sup> / <sub>16</sub>	42 <sup>1</sup> / <sub>8</sub>	16 <sup>3</sup> / <sub>4</sub>	4.23
HF6024T	60 x 24	52 <sup>3</sup> / <sub>4</sub>	18 <sup>1</sup> / <sub>8</sub>	9 <sup>1</sup> / <sub>16</sub>	27 <sup>1</sup> / <sub>16</sub>	54 <sup>1</sup> / <sub>8</sub>	16 <sup>3</sup> / <sub>4</sub>	5.52
HF7224T	72 x 24	64 <sup>3</sup> / <sub>4</sub>	18 <sup>1</sup> / <sub>8</sub>	9 <sup>1</sup> / <sub>16</sub>	33 <sup>1</sup> / <sub>16</sub>	66 <sup>1</sup> / <sub>8</sub>	16 <sup>3</sup> / <sub>4</sub>	6.81
HF4836T	48 x 36	40 <sup>3</sup> / <sub>4</sub>	30 <sup>1</sup> / <sub>8</sub>	15 <sup>1</sup> / <sub>16</sub>	21 <sup>1</sup> / <sub>16</sub>	42 <sup>1</sup> / <sub>8</sub>	28 <sup>3</sup> / <sub>4</sub>	7.52
HF6036T	60 x 36	52 <sup>3</sup> / <sub>4</sub>	30 <sup>1</sup> / <sub>8</sub>	15 <sup>1</sup> / <sub>16</sub>	27 <sup>1</sup> / <sub>16</sub>	54 <sup>1</sup> / <sub>8</sub>	28 <sup>3</sup> / <sub>4</sub>	9.81
HF7236T	72 x 36	64 <sup>3</sup> / <sub>4</sub>	30 <sup>1</sup> / <sub>8</sub>	15 <sup>1</sup> / <sub>16</sub>	33 <sup>1</sup> / <sub>16</sub>	66 <sup>1</sup> / <sub>8</sub>	28 <sup>3</sup> / <sub>4</sub>	12.09

FILTER SPECIFICATIONS

- Titus HEPA filters are designed specifically to fit the Titus TLF and RadiaTec diffusers manufactured after 6/10/07. These filters will not fit diffusers manufactured before that date.
- Filter efficiency is 99.99% with 0.3 micron particles per standard: IES-RP-CC-001.3 (Institute of Environmental Science & Technology)
- The filter resistance to airflow will be a maximum of 0.52" water gauge at 100 fpm. Refer to chart on page R69 for additional pressure drop values.
- Filter is scan tested for leaks at an air flow of 100 fpm
- Frame material is extruded anodized aluminum
- Filter has a downstream gel seal to mate with diffuser HEPA knife edge. Gel seal material is Blu-Jel.
- Filter media is 007 Dimple-pleat (ME-D0700). Pack style is 2" dimple pleat
- Filter is constructed of fire-rated materials per standard: UL-900 class 1
- Filter has a centerboard with (1) port for damper operation. Cadmium plated screw (included with filter) must be inserted into port while filter is in use.
- The filter maximum operating temperature is 250°F, and the maximum relative humidity (R.H.) is 100%
- Filters are non-hygroscopic

Nominal Filter Size										
24 x 12	CFM	6	7	11	15	19	22	30	37	44
	Pressure	0.080	0.11	0.15	0.21	0.26	0.32	0.42	0.53	0.68
36 x 12	CFM	10	13	20	26	33	40	53	66	79
	Pressure	0.08	0.11	0.15	0.21	0.26	0.33	0.43	0.54	0.69
48 x 12	CFM	14	19	28	38	47	56	75	94	113
	Pressure	0.07	0.09	0.14	0.19	0.29	0.36	0.42	0.60	0.68
60 x 12	CFM	18	25	37	49	62	74	98	123	148
	Pressure	0.08	0.11	0.15	0.21	0.27	0.33	0.44	0.54	0.70
72 x 12	CFM	23	30	46	61	76	91	122	152	182
	Pressure	0.07	0.09	0.14	0.19	0.25	0.30	0.42	0.52	0.66
24 x 24	CFM	25	33	50	66	83	100	133	166	200
	Pressure	0.07	0.09	0.14	0.19	0.25	0.30	0.42	0.52	0.66
36 x 24	CFM	44	59	88	118	147	176	235	295	353
	Pressure	0.07	0.09	0.14	0.19	0.25	0.30	0.42	0.52	0.66
48 x 24	CFM	63	85	127	170	212	254	338	423	508
	Pressure	0.07	0.10	0.14	0.20	0.25	0.30	0.42	0.52	0.66
60 x 24	CFM	83	110	166	221	276	331	442	552	663
	Pressure	0.07	0.10	0.14	0.20	0.25	0.31	0.42	0.52	0.66
72 x 24	CFM	102	136	204	272	340	409	545	681	817
	Pressure	0.08	0.10	0.14	0.20	0.25	0.31	0.42	0.52	0.66
48 x 36	CFM	113	150	226	301	376	451	601	752	902
	Pressure	0.08	0.10	0.15	0.21	0.26	0.31	0.42	0.52	0.66
60 x 36	CFM	147	196	294	392	490	589	785	981	1177
	Pressure	0.08	0.11	0.15	0.21	0.26	0.31	0.42	0.53	0.67
72 x 36	CFM	181	242	363	484	605	725	967	1210	1450
	Pressure	0.08	0.11	0.15	0.21	0.26	0.31	0.42	0.53	0.67

- Pressure loss values listed above are measured in inches of water gauge (w.g.)
- Pressure loss value is for an unused filter only. This value must be added to the diffuser pressure drop to determine total pressure.



HEPA-R FILTER

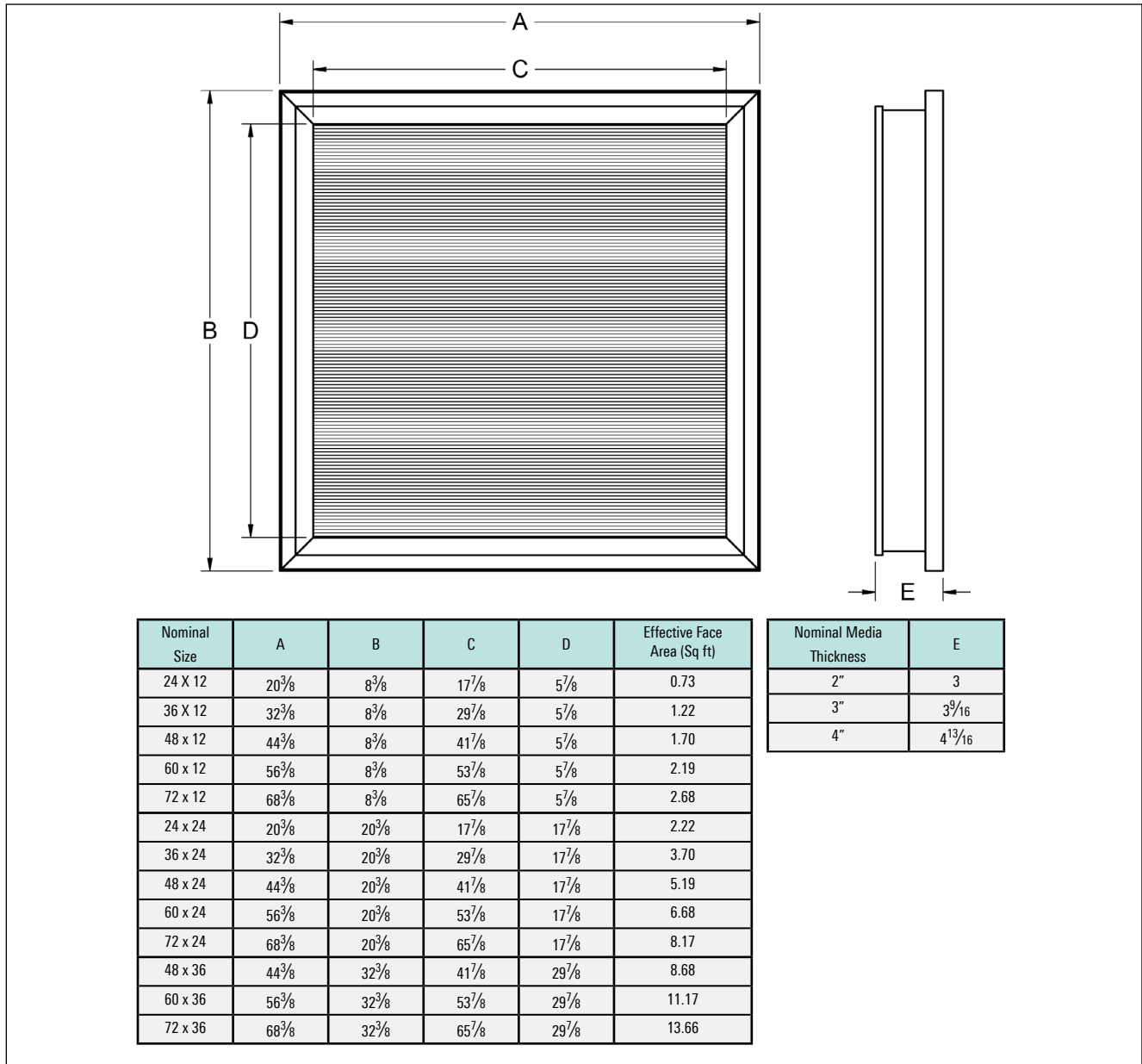

FILTER SPECIFICATIONS

- Titus HEPA-R filters are designed specifically to fit the Titus TLF-R-AA and TLF-R-SS diffusers
- This filter model is not compatible with TLF-AA, TLF-SS, RadiaTec-AL, and RadiaTec-SS models equipped with HEPA rack option
- Filter efficiency is 99.99% with 0.3 micron particles per standard: IEST-RP-CC-001 (Institute of Environmental Science & Technology). Tested in accordance with IEST-RP-CC-034.
- Frame material is extruded anodized aluminum
- Filter is equipped with an expanded metal grille
- Filter has a downstream gel seal to mate with diffuser HEPA knife edge. Gel seal material is self-healing non-flowing urethane.
- Filter media available in 2", 3" and 4" thick configurations
- Filter is constructed of fire-rated materials and meets UL-900 and UL 586 classifications
- The filter maximum operating temperature is 250°F, and the maximum relative humidity (R.H.) is 100%
- Filters are non-hygroscopic

HEPA-R FILTER WITH 2" MEDIA PACK THICKNESS

Nominal Filter Size										
24 x 12	CFM	6	7	11	15	19	22	30	37	44
	Pressure	0.04	0.04	0.07	0.09	0.12	0.14	0.19	0.23	0.28
36 x 12	CFM	10	13	20	26	33	40	53	66	79
	Pressure	0.04	0.05	0.08	0.10	0.12	0.15	0.20	0.25	0.30
48 x 12	CFM	14	19	28	38	47	56	75	94	113
	Pressure	0.04	0.05	0.08	0.10	0.13	0.15	0.20	0.25	0.30
60 x 12	CFM	18	25	37	49	62	74	98	123	148
	Pressure	0.04	0.05	0.08	0.10	0.13	0.16	0.21	0.26	0.31
72 x 12	CFM	23	30	46	61	76	91	122	152	182
	Pressure	0.04	0.05	0.08	0.10	0.13	0.16	0.21	0.26	0.31
24 x 24	CFM	25	33	50	66	83	100	133	166	200
	Pressure	0.05	0.07	0.10	0.14	0.17	0.21	0.28	0.34	0.42
36 x 24	CFM	44	59	88	118	147	176	235	295	353
	Pressure	0.05	0.07	0.11	0.15	0.18	0.22	0.29	0.37	0.44
48 x 24	CFM	63	85	127	170	212	254	338	423	508
	Pressure	0.06	0.08	0.11	0.15	0.19	0.22	0.30	0.37	0.45
60 x 24	CFM	83	110	166	221	276	331	442	552	663
	Pressure	0.06	0.08	0.11	0.15	0.19	0.23	0.30	0.38	0.46
72 x 24	CFM	102	136	204	272	340	409	545	681	817
	Pressure	0.06	0.08	0.11	0.15	0.19	0.23	0.31	0.38	0.46
48 x 36	CFM	113	150	226	301	376	451	601	752	902
	Pressure	0.06	0.08	0.12	0.16	0.20	0.24	0.32	0.40	0.48
60 x 36	CFM	147	196	294	392	490	589	785	981	1177
	Pressure	0.06	0.08	0.12	0.16	0.20	0.24	0.32	0.40	0.48
72 x 36	CFM	181	242	353	484	605	725	967	1210	1450
	Pressure	0.06	0.08	0.12	0.16	0.20	0.24	0.33	0.41	0.49

- Pressure loss values listed above are measured in inches of water gauge (w.g.)
- Pressure loss value listed is the initial resistance of a unused filter only. This value must be added to the diffuser (TLFR) pressure drop to determine the total pressure drop.

HEPA-R FILTER WITH 3" MEDIA PACK THICKNESS

Nominal Filter Size										
24 x 12	CFM	6	7	11	15	19	22	30	37	44
	Pressure	0.03	0.03	0.05	0.07	0.09	0.10	0.14	0.17	0.21
36 x 12	CFM	10	13	20	26	33	40	53	66	79
	Pressure	0.03	0.04	0.06	0.07	0.09	0.11	0.15	0.18	0.22
48 x 12	CFM	14	19	28	38	47	56	75	94	113
	Pressure	0.03	0.04	0.06	0.08	0.09	0.11	0.15	0.19	0.23
60 x 12	CFM	18	25	37	49	62	74	98	123	148
	Pressure	0.03	0.04	0.06	0.08	0.10	0.11	0.15	0.19	0.23
72 x 12	CFM	23	30	46	61	76	91	122	152	182
	Pressure	0.03	0.04	0.06	0.08	0.10	0.12	0.15	0.19	0.23
24 x 24	CFM	25	33	50	66	83	100	133	166	200
	Pressure	0.04	0.05	0.08	0.10	0.13	0.15	0.20	0.25	0.31
36 x 24	CFM	44	59	88	118	147	176	235	295	353
	Pressure	0.04	0.05	0.08	0.11	0.13	0.16	0.22	0.27	0.32
48 x 24	CFM	63	85	127	170	212	254	338	423	508
	Pressure	0.04	0.06	0.08	0.11	0.14	0.17	0.22	0.28	0.33
60 x 24	CFM	83	110	166	221	276	331	442	552	663
	Pressure	0.04	0.06	0.08	0.11	0.14	0.17	0.22	0.28	0.34
72 x 24	CFM	102	136	204	272	340	409	545	681	817
	Pressure	0.04	0.06	0.08	0.11	0.14	0.17	0.23	0.28	0.34
48 x 36	CFM	113	150	226	301	376	451	601	752	902
	Pressure	0.04	0.06	0.09	0.12	0.15	0.18	0.24	0.29	0.35
60 x 36	CFM	147	196	294	392	490	589	785	981	1177
	Pressure	0.04	0.06	0.09	0.12	0.15	0.18	0.24	0.30	0.36
72 x 36	CFM	181	242	353	484	605	725	967	1210	1450
	Pressure	0.05	0.06	0.09	0.12	0.15	0.18	0.24	0.30	0.36

- Pressure loss values listed above are measured in inches of water gauge (w.g.)
- Pressure loss value listed is the initial resistance of a unused filter only. This value must be added to the diffuser (TLFR) pressure drop to determine the total pressure drop.

HEPA-R FILTER WITH 4" MEDIA PACK THICKNESS

Nominal Filter Size										
24 x 12	CFM	6	7	11	15	19	22	30	37	44
	Pressure	0.02	0.03	0.04	0.06	0.08	0.09	0.12	0.15	0.18
36 x 12	CFM	10	13	20	26	33	40	53	66	79
	Pressure	0.02	0.03	0.05	0.06	0.08	0.10	0.13	0.16	0.19
48 x 12	CFM	14	19	28	38	47	56	75	94	113
	Pressure	0.02	0.03	0.05	0.06	0.08	0.10	0.13	0.16	0.19
60 x 12	CFM	18	25	37	49	62	74	98	123	148
	Pressure	0.02	0.03	0.05	0.06	0.08	0.10	0.13	0.16	0.20
72 x 12	CFM	23	30	46	61	76	91	122	152	182
	Pressure	0.02	0.03	0.05	0.07	0.08	0.10	0.13	0.16	0.20
24 x 24	CFM	25	33	50	66	83	100	133	166	200
	Pressure	0.03	0.04	0.07	0.09	0.11	0.13	0.17	0.22	0.26
36 x 24	CFM	44	59	88	118	147	176	235	295	353
	Pressure	0.03	0.05	0.07	0.09	0.12	0.14	0.18	0.23	0.28
48 x 24	CFM	63	85	127	170	212	254	338	423	508
	Pressure	0.04	0.05	0.07	0.09	0.12	0.14	0.19	0.24	0.28
60 x 24	CFM	83	110	166	221	276	331	442	552	663
	Pressure	0.04	0.05	0.07	0.10	0.12	0.14	0.19	0.24	0.29
72 x 24	CFM	102	136	204	272	340	409	545	681	817
	Pressure	0.04	0.05	0.07	0.10	0.12	0.15	0.19	0.24	0.29
48 x 36	CFM	113	150	226	301	376	451	601	752	902
	Pressure	0.04	0.05	0.08	0.10	0.13	0.15	0.20	0.25	0.30
60 x 36	CFM	147	196	294	392	490	589	785	981	1177
	Pressure	0.04	0.05	0.08	0.10	0.13	0.15	0.20	0.25	0.31
72 x 36	CFM	181	242	353	484	605	725	967	1210	1450
	Pressure	0.04	0.05	0.07	0.10	0.13	0.15	0.21	0.26	0.31

- Pressure loss values listed above are measured in inches of water gauge (w.g.)
- Pressure loss value listed is the initial resistance of a unused filter only. This value must be added to the diffuser (TLFR) pressure drop to determine the total pressure drop.

MERV14-R FILTER

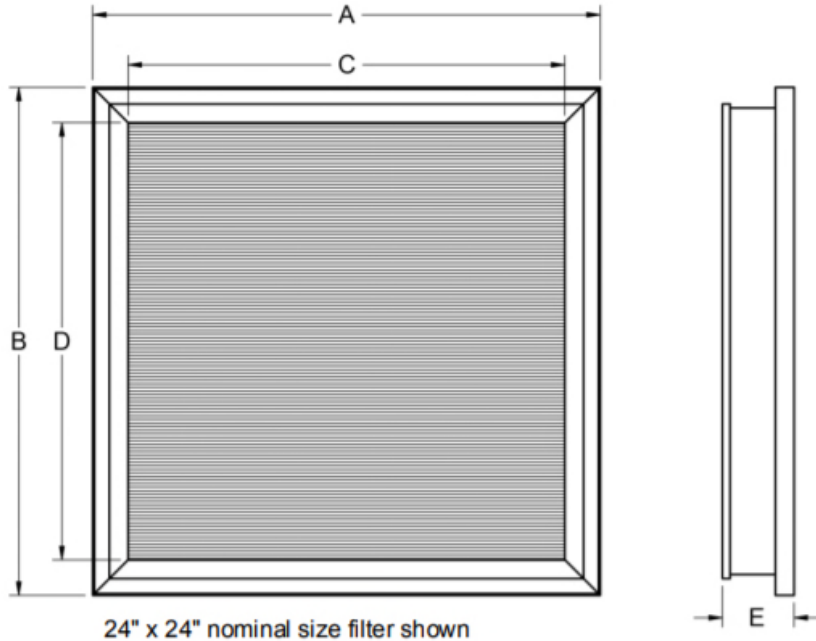

Nominal Size	A	B	C	D	Effective Face Area (Sq ft)
24 X 24	20 <sup>3</sup> / <sub>8</sub>	20 <sup>3</sup> / <sub>8</sub>	17 <sup>7</sup> / <sub>8</sub>	17 <sup>7</sup> / <sub>8</sub>	2.22
48 X 24	44 <sup>3</sup> / <sub>8</sub>	20 <sup>3</sup> / <sub>8</sub>	41 <sup>7</sup> / <sub>8</sub>	17 <sup>7</sup> / <sub>8</sub>	5.19

Nominal Media Thickness	E
2"	3

MERV 14 FILTER WITH 2" MEDIA PACK THICKNESS

Nominal Filter Size										
	24 x 24	CFM	25	33	50	66	83	100	133	166
Pressure		0.009	0.012	0.018	0.024	0.030	0.036	0.048	0.060	0.072
48 x 24	CFM	63	85	127	170	212	254	338	423	508
	Pressure	0.010	0.013	0.020	0.026	0.033	0.039	0.052	0.065	0.078

FILTER SPECIFICATIONS

- Titus MERV14-R filters are designed specifically to fit the RadiaTecR-AL, RadiaTecR-SS, TDCR-AA, TDCR-SS, TLF-AL, TLF-SS, TriTecR-AL, and TriTec-SS diffusers
- This filter model is not compatible with TLF-AA, TLF-SS, RadiaTec-AL, and RadiaTec-SS models equipped with HEPA rack option
- Filter efficiency is 95% with 0.3 micron particles per standard: IEST-RP-CC-001 (Institute of Environmental Science & Technology). Tested in accordance with IEST-RP-CC-034.
- Frame material is extruded anodized aluminum
- Filter is equipped with an expanded metal grille
- Filter has a downstream gel seal to mate with diffuser knife edge. Gel seal material is self-healing non-flowing urethane.
- Filter is constructed of fire-rated materials and meets UL-900 and UL 586 classifications
- The filter maximum operating temperature is 250°F, and the maximum relative humidity (R.H.) is 100%

MERV15-R FILTER

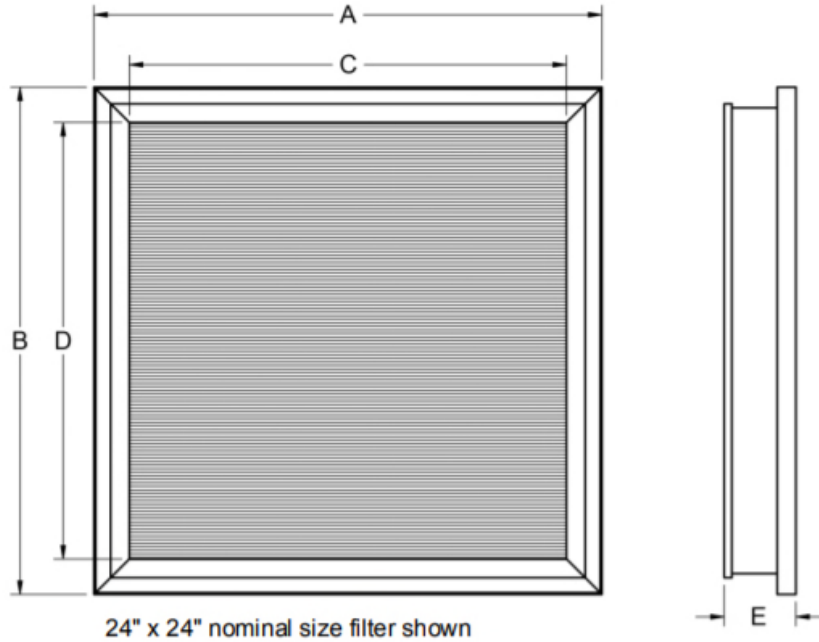

Nominal Size	A	B	C	D	Effective Face Area (Sq ft)
24 X 24	20 <sup>3</sup> / <sub>8</sub>	20 <sup>3</sup> / <sub>8</sub>	17 <sup>7</sup> / <sub>8</sub>	17 <sup>7</sup> / <sub>8</sub>	2.22
48 X 24	44 <sup>3</sup> / <sub>8</sub>	20 <sup>3</sup> / <sub>8</sub>	41 <sup>7</sup> / <sub>8</sub>	17 <sup>7</sup> / <sub>8</sub>	5.19

Nominal Media Thickness	E
2"	3

MERV 15 FILTER WITH 2" MEDIA PACK THICKNESS

Nominal Filter Size										
	24 x 24	CFM	25	33	50	66	83	100	133	166
Pressure		0.023	0.030	0.044	0.057	0.071	0.084	0.109	0.135	0.162
48 x 24	CFM	63	85	127	170	212	254	338	423	508
	Pressure	0.025	0.033	0.048	0.063	0.077	0.091	0.118	0.146	0.176

FILTER SPECIFICATIONS

- Titus MERV15-R filters are designed specifically to fit the RadiaTecR-AL, RadiaTecR-SS, TDCR-AA, TDCR-SS, TLF-AL, TLF-SS, TriTecR-AL, and TriTec-SS diffusers
- This filter model is not compatible with TLF-AA, TLF-SS, RadiaTec-AL, and RadiaTec-SS models equipped with HEPA rack option
- Filter efficiency is 95% with 0.3 micron particles per standard: IEST-RP-CC-001 (Institute of Environmental Science & Technology). Tested in accordance with IEST-RP-CC-034.
- Frame material is extruded anodized aluminum
- Filter is equipped with an expanded metal grille
- Filter has a downstream gel seal to mate with diffuser knife edge. Gel seal material is self-healing non-flowing urethane.
- Filter is constructed of fire-rated materials and meets UL-900 and UL 586 classifications
- The filter maximum operating temperature is 250°F, and the maximum relative humidity (R.H.) is 100%

ULPA-R FILTER

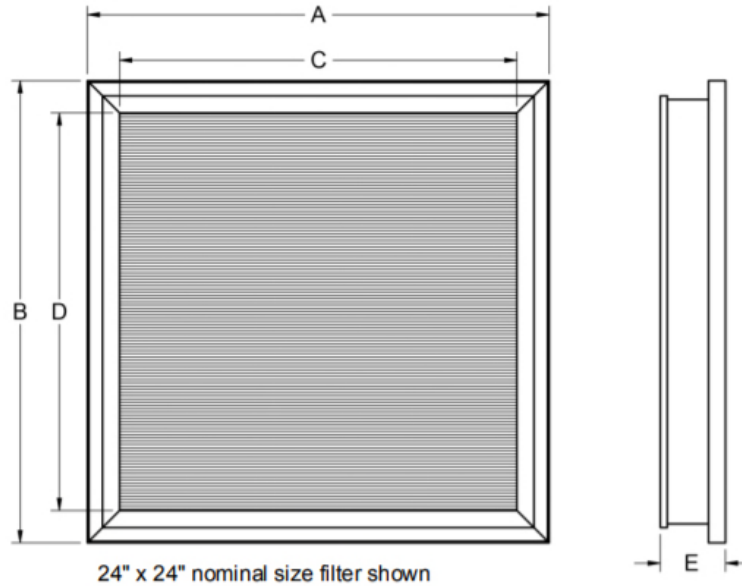

Nominal Size	A	B	C	D	Effective Face Area (Sq ft)	Nominal Media Thickness	E
24 X 24	20 <sup>3</sup> / <sub>8</sub>	20 <sup>3</sup> / <sub>8</sub>	17 <sup>7</sup> / <sub>8</sub>	17 <sup>7</sup> / <sub>8</sub>	2.22	2"	3
48 X 24	44 <sup>3</sup> / <sub>8</sub>	20 <sup>3</sup> / <sub>8</sub>	41 <sup>7</sup> / <sub>8</sub>	17 <sup>7</sup> / <sub>8</sub>	5.19	3"	3 <sup>9</sup> / <sub>16</sub>

Nominal Filter Size	ULPA FILTER WITH 2" MEDIA PACK THICKNESS									
24 x 24	CFM	25	33	50	66	83	100	133	166	200
	Pressure	0.07	0.10	0.15	0.19	0.24	0.29	0.39	0.49	0.59
48 x 24	CFM	63	85	127	170	212	254	338	423	508
	Pressure	0.08	0.11	0.16	0.21	0.27	0.32	0.42	0.53	0.64

Nominal Filter Size	ULPA FILTER WITH 3" MEDIA PACK THICKNESS									
24 x 24	CFM	25	33	50	66	83	100	133	166	200
	Pressure	0.05	0.07	0.10	0.13	0.16	0.20	0.26	0.33	0.40
48 x 24	CFM	63	85	127	170	212	254	338	423	508
	Pressure	0.05	0.07	0.11	0.14	0.18	0.22	0.29	0.36	0.43

FILTER SPECIFICATIONS

- Designed specifically to fit the TLFR-AA, TLFR-SS, TDCR-AA, TDCR-SS, TriTecR-AL, TriTec-SS, RadiaTecR-AL, and RadiaTecR-SS diffusers
- This filter model is not compatible with TLF-AA, TLF-SS, RadiaTec-AL, and RadiaTec-SS models equipped with HEPA rack option
- Filter efficiency is 99.9995% with 0.12 micron particles per standard: IEST-RP-CC-001 (Institute of Environmental Science & Technology). Tested in accordance with IEST-RP-CC-034.
- Frame material is extruded anodized aluminum
- Filter is equipped with an expanded metal grille
- Filter has a downstream gel seal to mate with diffuser knife edge. Gel seal material is self-healing non-flowing urethane.
- Filter media available in 2" and 3" configurations
- Filter is constructed of fire-rated materials and meets UL-900 and UL 586 classifications
- The filter maximum operating temperature is 250°F, and the maximum relative humidity (R.H.) is 100%
- Filters are non-hygroscopic

## TITUS OPERATING ROOM AIR DISTRIBUTION SYSTEM

### SYSTEM SIZING AND LAYOUT

#### SYSTEM CALCULATIONS STEPS

1. Determine room size
2. Determine desired number of air changes with a minimum of 4 outdoor air changes per hour for the SteriTec perimeter air curtain and the TLF internal diffusers
3. Determine SteriTec nominal system size
4. Determine desired total system cfm
5. Determine perimeter air curtain cfm
6. Determine internal diffuser cfm (usually 50 to 75 percent of the total cfm)
7. Select number of inlets and the location from the chart shown
8. Determine number TLF units and inlet size for each unit

ASHRAE guidelines point to providing continuous pillar of laminar airflow air distribution over the operating table and personnel as well as the surgical instrument table. These guidelines indicate the laminar airflow velocity should not exceed 25-35 fpm at the patient. The reason is the laminar flow should not overcome the natural plume of airflow from the body and allow the laminar flow to drive contaminants in a wound. Data has now been shown that space inside the "sterile field" can be used for lighting, gas connections, etc. This data shows that up to 30% of the primary supply diffuser array area may be allocated for non-diffuser use such as lights, gas columns, etc. but caution is advised.

The air curtain, or air wall, is recommended around the sterile field to stop contamination

from entrainment along the ceiling line and along the outer perimeter of the airflow coming down from the TLF supply diffusers. Most operating rooms are now recommended to be designed at a minimum 20 air changes per hour (ACH). The guidelines do not state a minimum. The airflow should be HEPA filtered and the operating room is normally at a positive pressure. Most codes call for the return grilles to be located at the external lower wall areas above the floor level in the corners of the room. For critical operating rooms a LineaTec air curtain should be added. The air curtain provides an air wall outside the laminar airflow zone to decrease entrainment or induction into the laminar airflow perimeter. The air curtain is normally selected for a terminal velocity of 50 fpm at 2 feet above the floor. The Titus LineaTec diffuser has a deflector that can be adjusted to deflect the air stream inward or slightly outward.

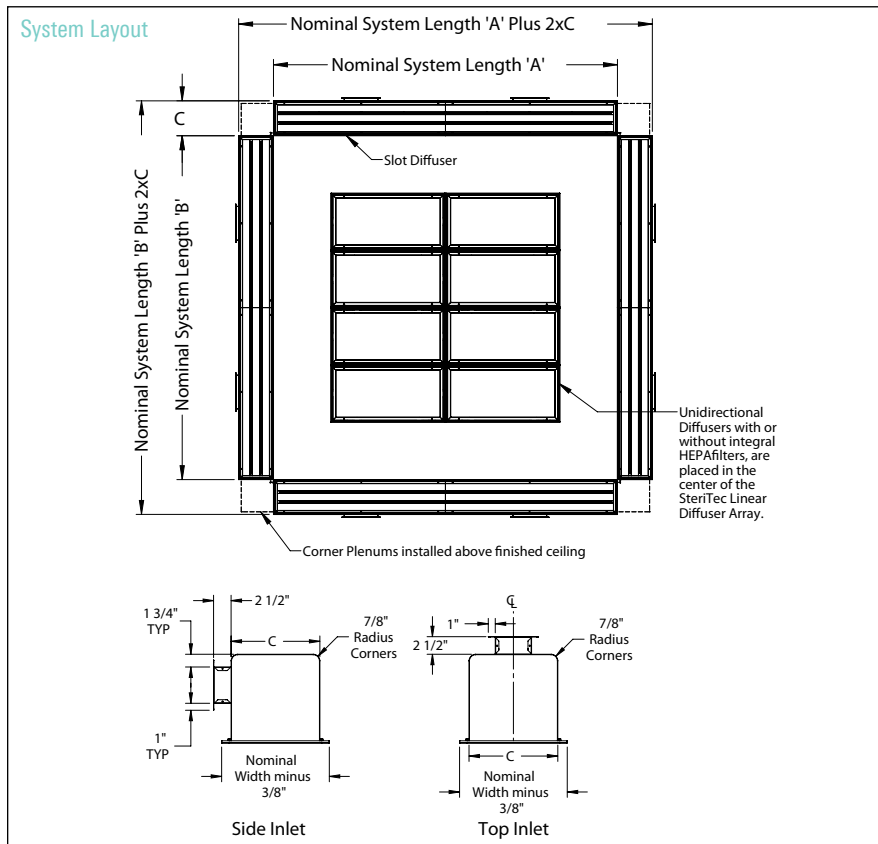

The operating room system specifications table provides SteriTec and TLF specifications based on different combinations of ACH and room dimensions. Rectangular sizes can also be used.

Air Changes Per Hour	Ceiling Height (ft.)	Room Dim. (ft.)	SteriTec Specifications								TLF Specifications					System Total cfm
			Dim. (ft.) A + B	Active Slots	System Layout*	Max Inlet Size (in.)	Inlets Required	Plenum Inlet Locations*	Total cfm	Throw (ft.) @ 50 fpm @ 2' A.F.	No. of units	Dim. (in.)	Inlet Size (in.)	Total cfm	Throw to 30 fpm	
20	10	30 x 38	12 x 12	2	A	60 x 8	4	2, 4, 6, 8	1,920	8	8	24 x 48	12	1,920	7	3,840
25	10	30 x 31	12 x 12	2	A	60 x 8	4	2, 4, 6, 8	1,920	8	8	24 x 48	12	1,920	7	3,840
30	10	28 x 27.5	12 x 12	2	A	60 x 8	4	2, 4, 6, 8	1,920	8	8	24 x 48	12	1,920	7	3,840
35	10	27 x 26	12 x 12	2	A	60 x 8	4	2, 4, 6, 8	1,920	8	8	24 x 48	12	1,920	7	3,840
20	10	44 x 45	14 x 14	2	B	42 x 8	8	1, 3, 4, 6, 7, 9, 10, 12	2,240	8	18	24 x 48	10	4,320	7	6,560
25	10	39 x 40	14 x 14	2	B	42 x 8	8	1, 3, 4, 6, 7, 9, 10, 12	2,240	8	18	24 x 48	10	4,320	7	6,560
30	10	36 x 37	14 x 14	2	B	42 x 8	8	1, 3, 4, 6, 7, 9, 10, 12	2,240	8	18	24 x 48	10	4,320	7	6,560
35	10	33 x 34	14 x 14	2	B	42 x 8	8	1, 3, 4, 6, 7, 9, 10, 12	2,240	8	18	24 x 48	10	4,320	7	6,560

\*Refer to page R58 for Plenum Inlet Location diagrams  
 \*\*cfm for 30 fpm see R52  
 A.F. = Above Floor

#### Required System Information

- Room Volume \_\_\_\_\_ ft<sup>3</sup>.
- Air Change per Hour \_\_\_\_\_.
- SteriTec Dimensions \_\_\_\_\_' x \_\_\_\_\_'.
- System Total cfm \_\_\_\_\_.
- SteriTec Total cfm \_\_\_\_\_.
- Number of TLF diffusers \_\_\_\_\_.
- cfm per TLF diffuser \_\_\_\_\_.



## OPERATING ROOM AIR DISTRIBUTION SYSTEM

The discussion presented in the application notes are intended as aids to heating and air conditioning engineers and designers with skill and knowledge about cleanroom design. Titus has no control over the system design and application of these critical environment products, a function that rightfully belongs to the designer.

Contaminated air outside the air curtain is prevented from entering the clean zone by the air curtain. Contaminated air in the clean zone is pushed down and outward by the laminar flow on the interior of the clean zone.

The interior of the system should have the highest room pressure due to velocities and air volume from the air diffusers.

Velocities should be kept to a maximum of 35 fpm at operating table height so the natural plumage velocity of the patient is not over powered and helps to prevent contaminants from getting into open wounds during surgery. The laminar flow diffuser should have quarter-turn fasteners and all internal parts shall be removable for cleaning and sterilization.

The entire operating room is usually under positive pressure created by dampering exhaust air and by providing extra makeup air. This helps to prevent an ingress of contaminated particles from outside the cleanroom. As doors or dividers are opened or parted, the positive internal pressure causes air to flow toward the lower external pressure outside the clean environment. The outward airflow forces particles away from the interior zone. Some hospital rooms are designed for negative pressure to keep contaminants from contaminating other hospital areas and endangering other people.

Plenums for LineaTec diffusers used in operating rooms usually have radiused corners. Corners are radiused with a  $\frac{3}{4}$ " radius to facilitate cleaning and to avoid areas where microorganisms can grow, later contaminating incoming clean air. The face of the LineaTec can be removed by rotating quarter-turn fasteners.

The entire plenum is then exposed to the maintenance worker. The plenum system is usually interconnected so a minimum number of inlets can be utilized for incoming air from the air handler.

Corner transitions are utilized so the plenum can be continuous, even at the corners. Corner transitions found on Titus plenum systems are covered on the operating room side by a cover plate. When the plate is removed, the entire plenum corner is exposed for easy cleaning. The cover plate itself can be put in an autoclave for sterilization. Some competitive models utilize an elbow behind the ceiling as corner transitions. To clean the corner transitions, the maintenance worker must reach around the corner in areas that are hidden from sight; this is not recommended.

The operating room design engineer determines the number of ACH based on the cleanliness level desired and current industry standards. Plenum inlets are sized so the maximum inlet velocity is in the 500 fpm range. Inlets can be lengthened and made longer to reduce entrance velocities or multiple inlets can be used. Plenum velocities should be kept as low as possible to facilitate automatic balancing of the air curtain. The 800 fpm range is considered top end, 400 to 500 fpm is desirable.

Total room airflow should be divided between the perimeter air curtain and the center diffusers. The perimeter air curtain should be supplying air between 25 to 50 cfm per foot. HEPA filters should be located remotely.

The standard material of construction is 304 stainless steel. The 304 stainless steel offers durability and an attractive appearance; plus it can withstand manual sterilization using harsh chemicals normally encountered for this purpose. The standard finish is #04 mill finish.

Manual balancing dampers should be sufficient to allow balancing of individual duct branches. Design flow rates to the interior clean zone should be established through normal balancing procedure by a certified air balancing professional. The perimeter zone should be adjusted to obtain the required cfm per foot as designed.



## CLEAN SPACE

A defined area in which particle concentration and environmental conditions are controlled at or below specified limits (ASHRAE 2011 Handbook).

## CLEANLINESS CLASSIFICATION (CLASS)

Allowable particle concentrations per cubic meter over a range of particle sizes as outlined in ISO standard 14644-1 (see chart below). For example, an ISO Class 5 cleanroom is defined as a space where the particle concentration does not exceed 100,000 particles per cubic meter for 0.1µm particles, or 832 particles per cubic meter for 1µm particles.

## CLEANROOM

An enclosed area especially constructed for environmentally controlling airborne particulates, temperature, humidity, air pressure, airflow patterns, air motion, vibration, noise, viable organisms, and lighting (ASHRAE 2011 Handbook).

## FIRST AIR

Air supplied directly from the HEPA filter before it passes over any work location (ASHRAE 2011 Applications Handbook).

## HIGH-EFFICIENCY FILTER (HEPA)

A filter with an efficiency in excess of 99.97% of 0.3 micrometer, (ASHRAE 2011 Applications Handbook).

## MAKEUP AIR

Air introduced to the secondary (recirculated) air system for ventilation, pressurization and replacement of exhaust air.

## PARTICLE CONCENTRATION

The number of individual particles per unit volume of air (ASHRAE 2011 Applications Handbook).

## PARTICLE SIZE

The apparent maximum linear dimension of a particle in the plane of observation (ASHRAE 2011 Handbook).

## SECONDARY AIR

Air that recirculates through the workspace (ASHRAE 2011 Applications Handbook).

## ULTRALOW-PENETRATION AIR FILTER (ULPA)

A filter with a minimum efficiency of 99.999 percent of 0.12 micrometer particles, (ASHRAE 2011 Applications Handbook).

## UNIDIRECTIONAL FLOW

Formerly called laminar flow. Air flowing at constant and uniform velocity in the same direction (ASHRAE 2011 Handbook).

## WORKSTATION

An open or enclosed work surface with direct air supply (ASHRAE 2011 Handbook).

Air Cleanliness Class Limits U.S. Federal Standard 209

Airborne Particle Concentration Limits from ISO Standard 14644-1						
ISO 14644-1 Class	0.1 µm	0.2 µm	0.3 µm	0.5 µm	1.0 µm	5.0 µm
Particles per m <sup>3</sup>						
1	10	2				
2	100	24	10	4		
3	1,000	237	102	35	8	
4	10,000	2,370	1,020	352	83	
5	100,000	23,700	10,000	3,520	832	29
6	1,000,000	237,000	102,000	35,200	8,320	293
7				352,000	83,200	2,930
8				3,520,000	832,000	29,300
9				35,200,000	8,320,000	293,000

Note: Values shown are the concentration limits for particles equal to and larger than the sizes shown.  
 $C_p = 10^N(0.1/D)^{2.5}$  where  $C_p$  = concentration limits in particles/m<sup>3</sup>,  $N$  = ISO class, and  $D$  = particle diameter in µm.

Air Cleanliness Class Limits U.S. Federal Standard 209

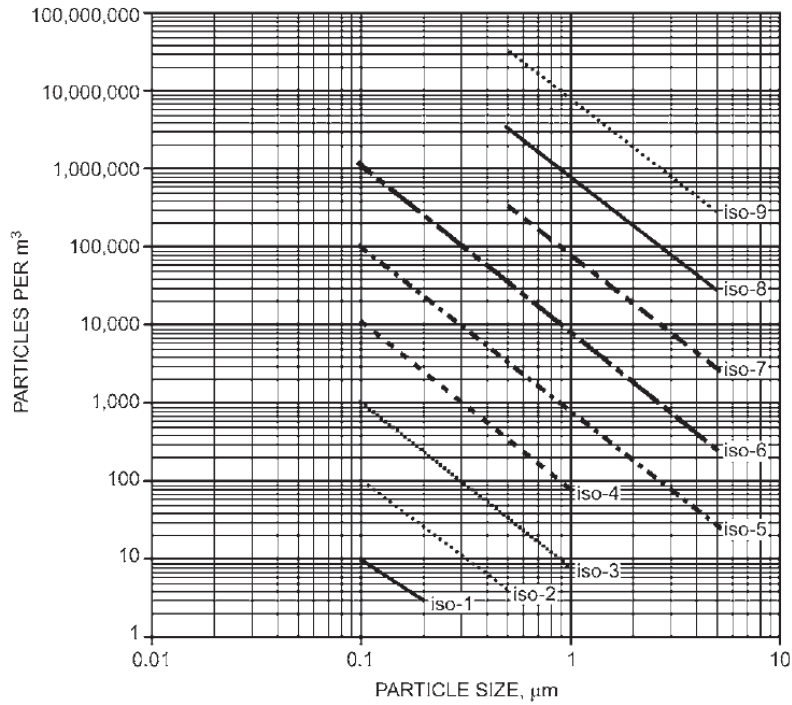

**Air Cleanliness Classifications ISO Standard 14644-1**

### THRC

- Ideal airflow pattern delivers clean air to the breathing zone
- 560 CFM – 800 CFM High Flow Configuration
- 70 CFM – 400 CFM Low Flow Configuration
- 99.99% Medical Grade HEPA Filter
- 99.995% ULPA Filtration Option
- Antimicrobial MERV 8 Pre-filter
- Filter Replacement Indicator Light
- Quiet operation and simple maintenance
- Durable welded steel cabinet
- Optional High Intensity UV-C Germicidal Lighting
- Locking Caster Wheels



THRC

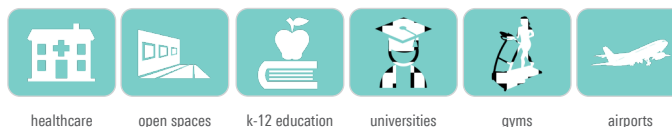

healthcare    open spaces    k-12 education    universities    gyms    airports

 See website for Specifications

### MODELS:

- THRC / High Flow
- THRC / Low Flow

### FINISHES:

Standard Finish - #26 White

### OVERVIEW

The Titus HEPA Room Air Cleaner (THRC) is the ideal solution to improve indoor air quality by providing continuous filtration within the space. When equipped with the optional Germicidal Ultraviolet light, the THRC provides superior defense against the spread of infectious airborne particles. The quiet operation and durable welded steel cabinet makes the THRC ideal for use in classrooms, open and individual offices, restaurants, retail spaces, and other high occupancy areas.

### HVAC SYSTEM ABATEMENT STRATEGIES

HVAC systems are not capable of addressing all aspects of infection control. However, they do impact the distribution and bioburden of infectious aerosols. Increased ventilation, as well as enhanced air filtration and cleaning (e.g. UVGI) technologies have been proven to reduce the risk of transmission of airborne aerosols.

### INCREASED VENTILATION AND ENHANCED FILTRATION

ASHRAE recommends considering that during times when there is an elevated risk of infectious aerosols “outside air for ventilation be increased to as much as the HVAC system can accommodate and still maintain acceptable indoor conditions during occupied hours”. This statement underscores the fact that existing HVAC systems are often limited in their cooling capacity and can properly condition only a limited amount of outdoor air during periods of near peak cooling or heating demand. The THRC solves this problem by increasing the number of clean air changes within a space without increasing load on existing heating and cooling equipment.

The THRC increases the volume of clean air changes by recirculating room air through high efficiency (HEPA or ULPA filters). This affects the spread of infectious aerosols through dilution which reduces the volume of potentially infectious particles within the space. The airflow pattern of the THRC delivers the clean air changes into the breathing zone where it is most important for occupants.

Another key aspect to reducing concentration of airborne contaminants by dilution is high efficiency filtration. Although MERV 13 filters are 90% effective at capturing aerosol droplets larger than 1µm, they are less than 75% effective capturing particles smaller than 1µm. The THRC

TABLE 1 – AIR CHANGES PER ROOM VOLUME

Model	High Flow Configuration				Low Flow Configuration				
	Room Dims.	10'x'8'x10'	12'x12'x10'	12'x15'x10'	15'x15'x10'	10'x'8'x10'	12'x12'x10'	12'x15'x10'	15'x15'x10'
Room Volume	800 ft <sup>3</sup>	1440 ft <sup>3</sup>	1800 ft <sup>3</sup>	2250 ft <sup>3</sup>	800 ft <sup>3</sup>	1440 ft <sup>3</sup>	1800 ft <sup>3</sup>	2250 ft <sup>3</sup>	
Air Change Rate	42- 60	23 - 33	18 - 26	14 - 21	5 - 30	2 - 16	2 - 13	1.5 - 10	

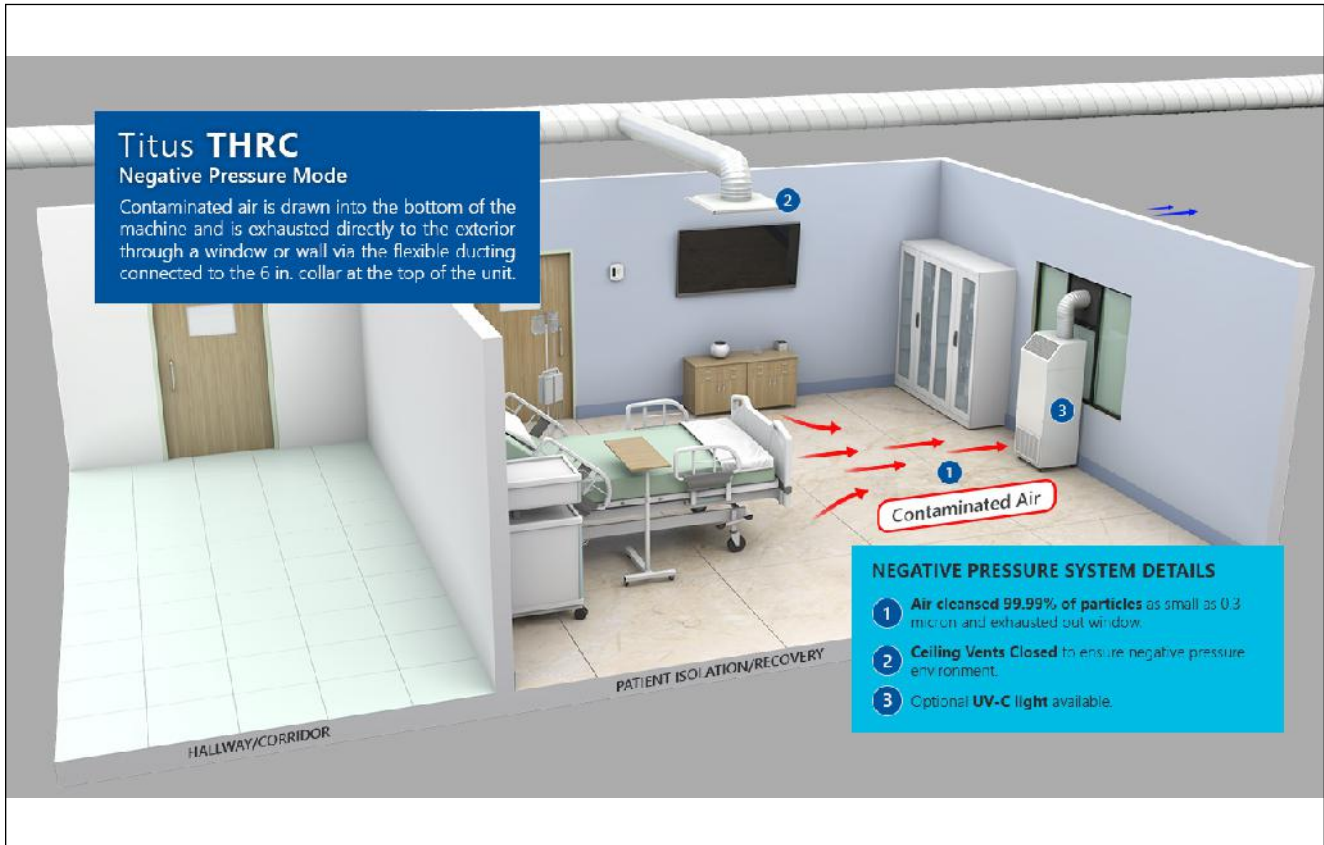

is equipped with an Antimicrobial MERV 8 pre-filter and HEPA filter that is 99.99% efficient for particles as small as 0.3µm. This level of filtration is important as the size of most infectious aerosols are 0.5-5µm, and the very smallest of those particles have been shown to remain airborne for as much as 40 hours, and can continue to remain airborne if not captured by a filter. The optional ULPA filters can increase filtration efficiency to 99.9995% at 0.15µm, further improving capture rate.

### ENHANCED AIR CLEANING

ASHRAE also endorses the use of ultraviolet germicidal irradiance (UVGI) as an effective technology for de-activating the airborne viruses, bacteria, and fungal spores both in HVAC systems and the occupied space. The THRC can come equipped with optional UV-C lighting (254 nm wavelength) and further enhances the cleanliness of the recirculated air. UV-C bulbs in the THRC are rated for 9,000 hours of continuous usage, and are placed upstream of the HEPA filter to ensure all captured particles are inactivated.

### EXHAUST AND PARTIAL EXHAUST APPLICATIONS

The THRC can be set up for two different exhaust setups. THRC is supplied with a 6-inch duct collar, underneath a blank-off plate on the top of the unit. By removing the blank-off and installing the 6-inch duct collar 50% of the air can be recirculated and the remaining 50% can be exhausted. A 100% exhaust configuration can be achieved by replacing the supply grille with the 8-inch ducted collar accessory. These configurations can help convert standard patient room to isolation rooms when outbreaks occur and a shortage of available Airborne Infection Isolation (AII) rooms occurs. In order to achieve this conversion, the requirements of FGI guidelines/ASHRAE Standard 170 must be achieved. These requirements include achieving total of 12 exhaust air changes and maintaining a negative pressure of at least 0.01 in wg. The addition of a THRC in either the 100% or 50%/50% exhaust configurations can help systems that were not initial designed for isolation room use to be converted on an as needed basis and stored for future outbreaks when not required. Portable construction and easy maintenance procedures make cleaning and disinfecting the THRC simple and efficient.



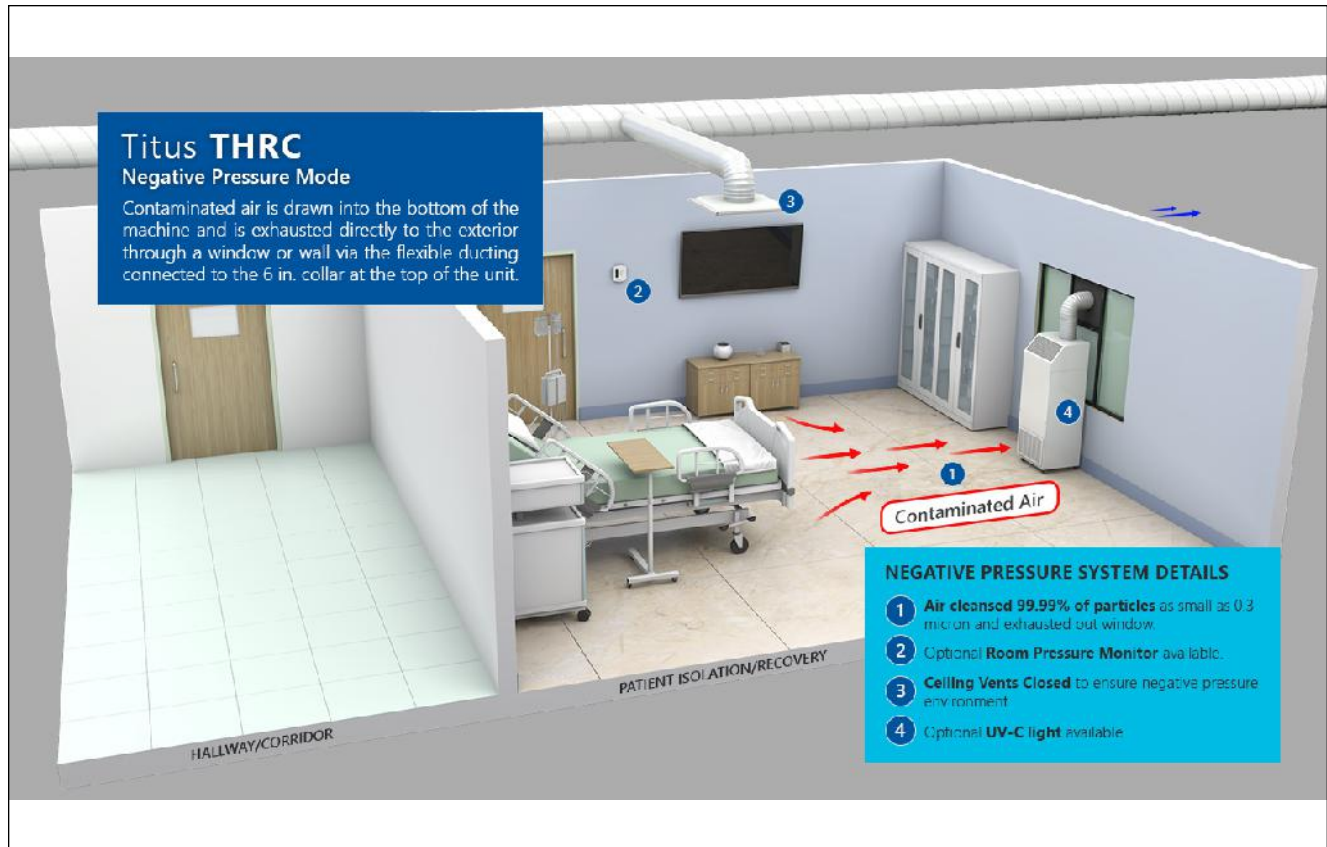

## STANDARD FEATURES

- 560 CFM – 800 CFM High Flow Configuration
- 70 CFM – 400 CFM Low Flow Configuration
- 99.99% Medical Grade HEPA Filter
- Filter Replacement Indicator Light
- Antimicrobial MERV 8 Pre-filter
- 6in Duct Collar and Blank-off for 50-50 Supply/Exhaust Configuration
- 120V or 220V Configurations with Power Cord
- Durable Welded, Powder Coated Steel Cabinet
- Eggcrate Supply Grille
- Quiet Operation
- Locking Caster Wheels

## OPTIONS & ACCESSORIES

- High Intensity UV-C Germicidal Lighting
- 99.995% ULPA Filter
- Carbon MERV 8 Pre-filter
- 8in Duct Collar for 100% Exhaust Configuration

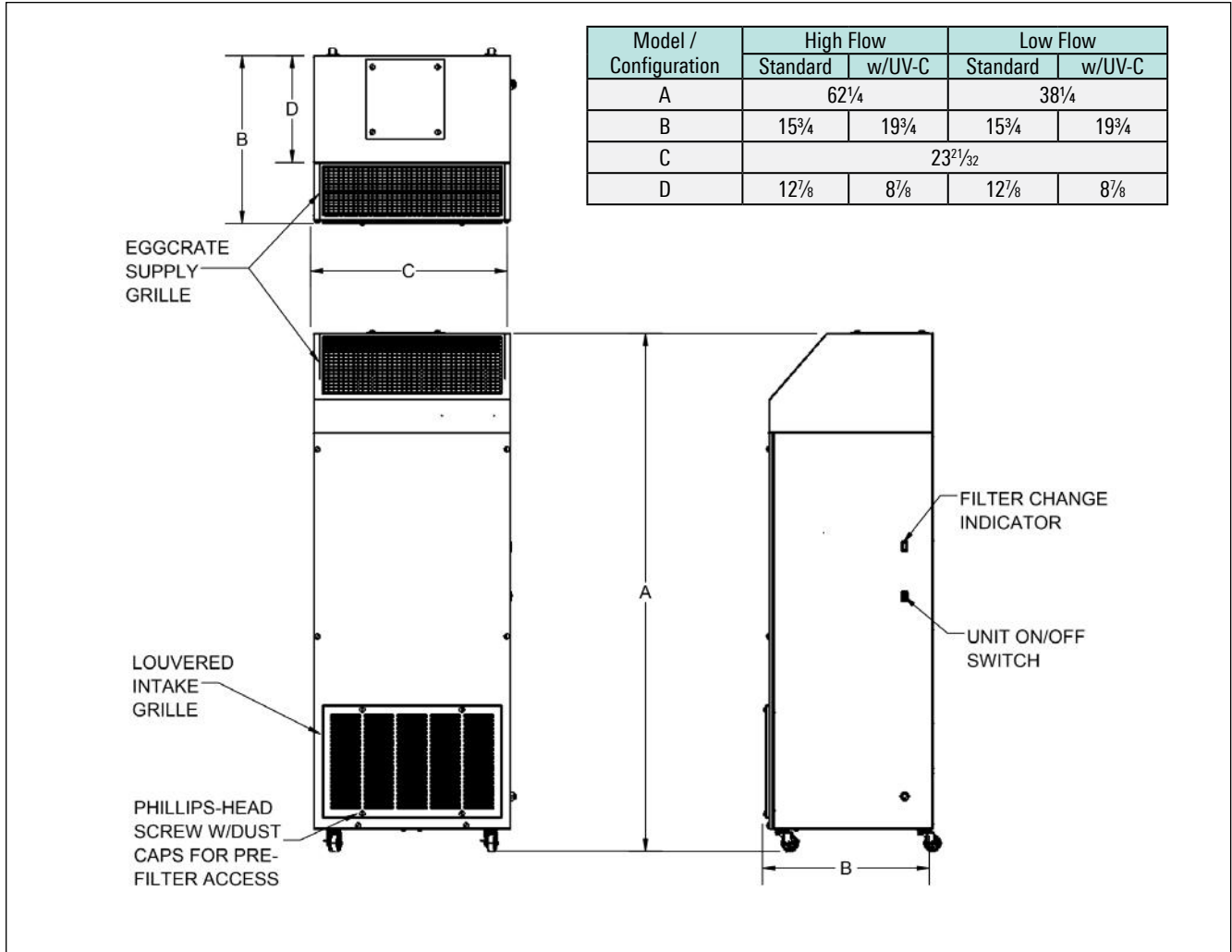

**THRC / HIGH & LOW CONFIGURATIONS**

High Flow Configuration				
Description	120V w/ UV-C	220V w/ UV-C	120V	220V
Airflow CFM (m <sup>3</sup> /hr) 3-Speed	Low: 560 (951) ± 10%			
	Medium: 690 (1172) ± 10%			
	High: 800 (1359) ± 10%			
Power Requirements	8.0 Amps @ 115V/ 60 Hz	4.0 Amps @ 208-230V/60 Hz	6.9 Amps @ 115V/ 60 Hz	3.5 Amps @ 208-230V/60 Hz
Unit Weight lbs. (kg.)	200 (91)		175 (79)	
UL Listed (E152685)	Pending	Pending	Yes	Pending

Low Flow Configuration				
Description	120V w/ UV-C	220V w/ UV-C	120V	220V
Airflow CFM (m <sup>3</sup> /hr) Variable Speed	Min: 70 (119) ± 10%			
	Max: 400 (679) ± 10%			
Power Requirements	4.5 Amps @ 115V/ 60 Hz	2.1 Amps @ 208-230V/60 Hz	4.4 Amps @ 115V/ 60 Hz	2.0 Amps @ 208-230V/60 Hz
Unit Weight lbs. (kg.)	100 (45)		90 (41)	
UL Listed (E152685)	Pending	Pending	Pending	Pending

**TABLE 1 – AIR CHANGES PER ROOM VOLUME**

Model	High Flow Configuration				Low Flow Configuration			
Room Dims.	10'x'8'x10'	12'x12'x10'	12'x15'x10'	15'x15'x10'	10'x'8'x10'	12'x12'x10'	12'x15'x10'	15'x15'x10'
Room Volume	800 ft <sup>3</sup>	1440 ft <sup>3</sup>	1800 ft <sup>3</sup>	2250 ft <sup>3</sup>	800 ft <sup>3</sup>	1440 ft <sup>3</sup>	1800 ft <sup>3</sup>	2250 ft <sup>3</sup>
Air Change Rate	42- 60	23 - 33	18 - 26	14 - 21	5 - 30	2 - 16	2 - 13	1.5 - 10





PERFORMANCE DATA

critical environment diffusers

Redefine your comfort zone.™ | [www.titus-hvac.com](http://www.titus-hvac.com)

R

PERFORMANCE DATA

R101



PERFORMANCE DATA

critical environment diffusers

Redefine your comfort zone.™ | [www.titus-hvac.com](http://www.titus-hvac.com)

R

PERFORMANCE DATA

R102



PERFORMANCE DATA

critical environment diffusers

Redefine your comfort zone.™ | [www.titus-hvac.com](http://www.titus-hvac.com)

R

PERFORMANCE DATA

R103

## Icons

## critical environment diffusers



for use in vital areas within hospitals & patient rooms to remove contaminants from the air

hospitals



designed for use in cleanroom applications to remove contaminants

cleanrooms



can be used in healthcare facility common areas such as: nurse's stations, patient rooms and waiting rooms

healthcare



for use in hospital operating rooms to protect the patient from contaminated air

surgical



for use in laboratory environments with exhaust hoods, pharmaceutical manufacturing and other biotechnological facilities

research labs

